

HALFEN FRIMEDA LIFTING ANCHOR SYSTEM **Technical Product Information**





We are one team. **We are Leviat.**

Leviat is the new name of CRH's construction accessories companies worldwide.

Under the Leviat brand, we have united the expertise, skills and resources of HALFEN and its sister companies to create a world leader in fixing, connecting and anchoring technology.

The products you know and trust, including the HALFEN FRIMEDA Lifting anchor system, will remain an integral part of Leviat's comprehensive brand and product portfolio. As Leviat, we can offer you an extended range of specialist products and services, greater technical expertise, a larger and more agile supply chain and better, faster innovation.

By bringing together CRH's construction accessories family as one global organisation, we are better equipped to meet the needs of our customers, and the demands of construction projects, of any scale, anywhere in the world.

This is an exciting change. Join us on our journey.

Read more about Leviat at Leviat.com



Our product brands include:

Ancon[®]

HALFEN

PLAKA



60
locations

sales in
30+
countries

3000
people worldwide

Imagine. Model. Make.

Leviat.com

HALFEN FRIMEDA LIFTING ANCHOR SYSTEMS

Certified quality – Connected to safety.



The HALFEN FRIMEDA Lifting anchor system meets the requirements of European Machinery Directive (MD) 2006/42/EC. The directive defines the required steel-load-bearing properties for anchor systems used for lifting.

In addition, the HALFEN FRIMEDA transport anchors already meet the current EN 13155 standard; "Cranes – Safety – Non-fixed load lifting attachments".

Important changes for use in the UK:

The UK is transitioning to its own UK based approval system and, as a result, from January 2023 will no longer accept CE marking. Leviat already has new UKCA marking in place and from 2023 at the latest, the UKCA mark will also be applied directly to the lifting systems, as required by the UKCA regulations. The conformity assessment processes and standards that can be used to demonstrate conformity under UKCA marking are aligned with those required for CE marking, so there is no difference in performance or testing requirements.



EN 13155 is the first harmonized European standard and is therefore a product standard setting out detailed requirements for specified "partly completed machinery", in this case Non-fixed load lifting attachments. The standard serves to coordinate with the Machinery Directive, and on a European technical level, now also considers the decisive composite material concrete, in precast concrete components.

Previous, as a supplement to the Machinery Directive, the German guideline VDI/BV-BS 6205 regulated the resistances of embedded anchors required for safe use of lifting anchor systems. In the process of publishing EN 13155, the guideline was also fundamentally revised. As before, it continues to provide basics and important additional information for manufacturing, design and use of lifting anchor systems. The VDI/BV-BS 6205 continues to represent recognised standards of technology in this field; applicable, valid technical specifications will continue to be observed. In combination with EN 13155, we therefore guarantee a consistent high level of safety when using HALFEN Lifting anchors and lifting anchor systems.

All our lifting anchor systems are identified with the CE marking.



MD 2006/42/EC
EN 13155

This confirms conformity with MD 2006/42/EC and EN 13155. This catalogue is an installation and application instruction as defined in EN 13155. Our lifting anchors and lifting anchor systems are subject to a system of regular internal and external monitoring. We guarantee consistent high quality and maximum safety for you, your company and your employees.

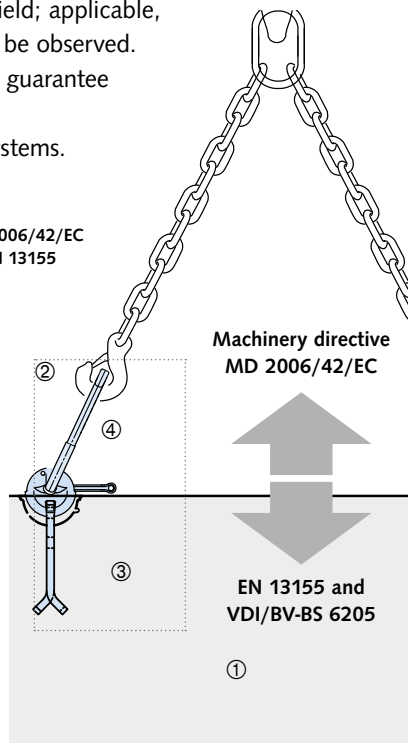

- ① Precast element
- ② Lifting anchor system ③+④
- ③ Lifting anchor
- ④ Lifting link

Dependability

High ductility – High performance even in extreme situations



Specially tempered steel guarantees extensive elastic and plastic properties. The required unique steel compositions to achieve these product characteristics are specified by us. Numerous tests and many years of experience guarantee the best possible results and maximum reliability in all applications.

Toughness at subzero temperatures – Same material characteristics irrespective of weather conditions



The special composition of the steel ensures constant identical characteristics (temperature independent). The steel used by us exceeds the requirement of DIN EN 10025.

Quality control – for reliable application



By specifying products, materials and continual raw material and product monitoring, and testing by renowned independent bodies and universities, our customers can be sure that the quality and properties of all our anchors remain consistent.

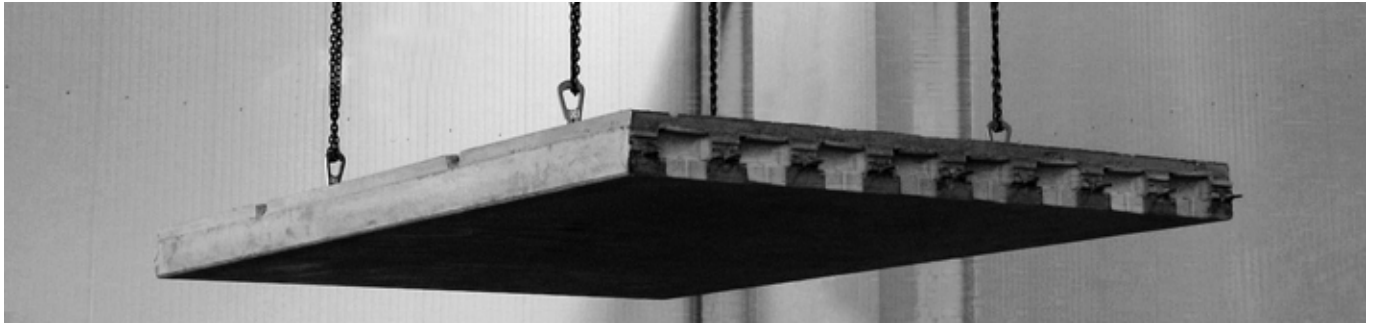

CONTENT

General	
Certified quality	6-9
System overview	10-13
Product range	14-16
HALFEN FRIMEDA Lifting anchor system – installation and application	
Safety regulations / Identification	17
Anchor selection / Load calculation	18-22
Anchor installation	23
Tables, load class allocation	24
HALFEN FRIMEDA Lifting anchor	
TPA-FS Spread anchor	25-32
TPA-FZ Two-hole anchor	33-35
TPA-FA /TPA-FE Double/single shoulder erection anchor (tilt-up)	36-38
TPA-FU Universal anchor 1,25-12	39
TPA-FF Flat foot anchor	40-41
TPA-FP Plate anchor	42
TPA-FX Sandwich panel anchor	43-44
TPA-FD Double-head (column) anchor	45
HALFEN FRIMEDA Recess former, holding plates, holding bolts and accessories	
Installation and application	46-48
Types / allocation	49-50
HALFEN FRIMEDA Ring clutches	
Application instructions	51-52
TPA-R1 Ring clutch with shackle for manual release	53
TPA-R2/ TPA-R3 Ring clutch with wire cables	53
Checking the connection fittings	54
TPA-F1 Ring clutch with pneumatic release	55-56
TPA-F2 Ring clutch with manual remote control with Bowden cable	57-58
Accessories	
Application examples / further HALFEN products	59
Contact/Technical support	63

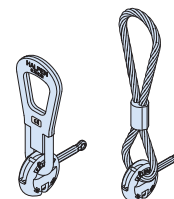
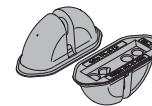
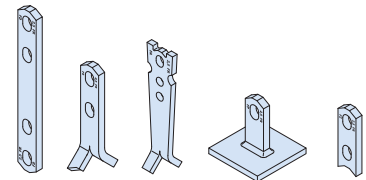
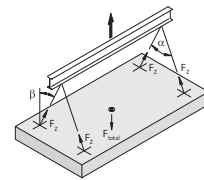

HALFEN FRIMEDA LIFTING ANCHOR SYSTEM

System Advantages Overview

The HALFEN FRIMEDA Lifting anchor is a high quality and cost effective system for transporting all types of concrete elements. The tilt-up anchor allows lifting horizontally-cast wall elements upright when not using a tilting table. A remote release is also available; this increases efficiency and safety when lifting tall elements. Our extensive range of anchors and accessories provide the perfect solution for nearly all lifting applications.



Fast, simple, safe

The HALFEN FRIMEDA Quick-clutch lifting system guarantees simple, safe and fast connection and disconnection of lifting links and anchors.

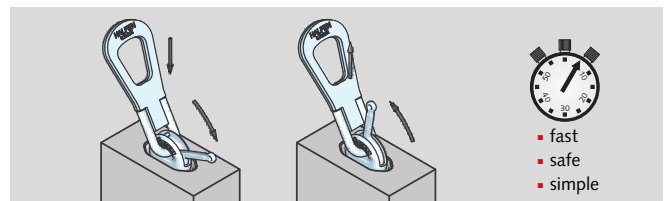

Load range

The HALFEN FRIMEDA Quick-clutch lifting system can be used for load classes from 1,25 up to 26,0t.

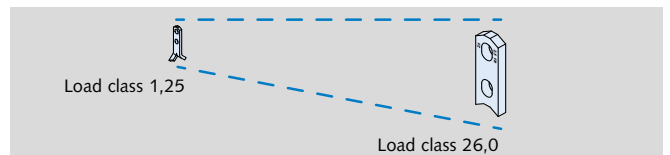

High quality material

We offer a wide selection of anchors in high quality killed steel "special grade" with an alloy composition specially designed for transport applications in any environment.

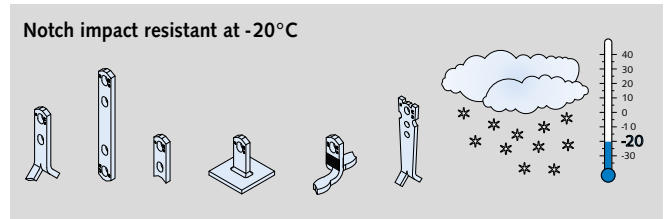

Corrosion protection

Apart from the mill-finished standard type, the majority of transport anchors in the HALFEN FRIMEDA range are available in a zinc-galvanized and in a special, stainless steel type.

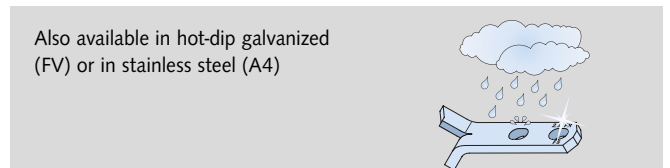

Wide range of accessories

A wide range of accessories, especially recess formers, guarantee cost-effective use in all applications.

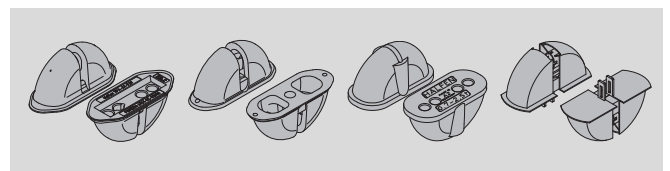

HALFEN FRIMEDA TPA – perfect for most applications

HALFEN FRIMEDA TPA is suitable for lifting and transporting precast elements regardless of shape and size.

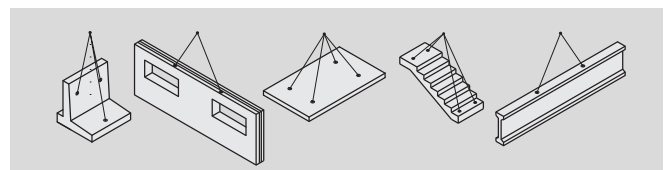

Tilt-up of wall elements

The HALFEN FRIMEDA Erection anchor is the ideal solution for erecting horizontally transported walls on a construction site.

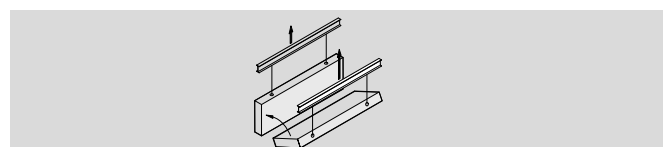

HALFEN FRIMEDA LIFTING ANCHOR SYSTEM

System Advantages Overview

Avoid mix-ups

Even after installation, the load class, anchor length and the manufacturer's identification mark are easily and correctly identified on all anchors. This and the unique head shape ensures mix-ups are avoided!

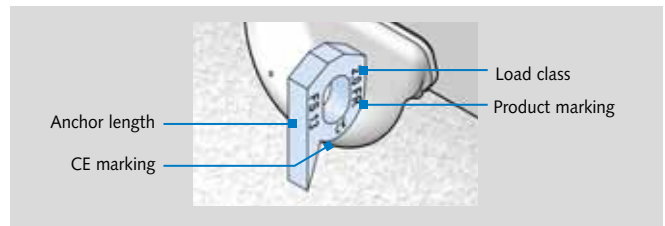

Matching components

Anchor and lifting link are designed to ensure that only components with the same load class can be used together. The same principle applies to the design of the recess formers.

Load class ring clutch	1,25	2,5	5,0	10,0	26,0
Load class recess former	1,25	2,5	5,0	10,0	26,0
Load class anchor	1,25	1,4 2,5	5,0	7,5 10,0	12,5 14,0 17,0 22,0 26,0

System safety

Maximal safety is only assured when using system components from the same manufacturer.

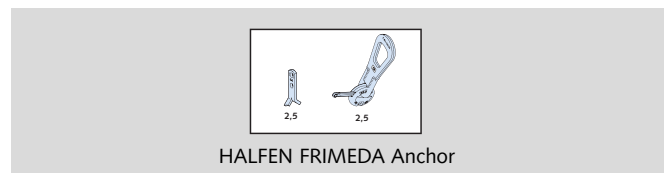

Steel failure safety factor

All anchors are sufficiently dimensioned to three times the safety factor for steel failure.

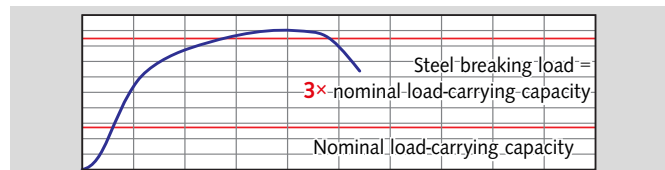

Quality control

An extensive certified quality system monitors the complete production process; starting with incoming raw materials; monitoring at every stage of production and final check of the finished product.



Independent testing

Extensive meticulous testing of every part of the system by independent certification bodies and universities.



CE conform

All HALFEN Lifting links and anchors are CE marked. This guarantees compliance with the relevant European regulations.



Certified

Our facilities in Germany and Poland are Quality Management certified in accordance with DIN EN ISO 9001:2015, Certificate no. SZI-Q-1765-A



HALFEN FRIMEDA LIFTING ANCHOR SYSTEM

Quality – from start to finish.

Quality and safety are the ultimate targets in production of original HALFEN FRIMEDA Lifting anchors. The fundamental requirements for production of all of our products are quality and safety. Therefore all our production facilities are ISO 9001 certified.

On the one hand this involves continual inspection, machine maintenance and quality testing during the manufacturing process, and on the other hand it involves stringent quality control procedures of incoming raw materials right through to delivery of the finished product.

Quality always comes first for our products and is guaranteed during every step of production.

The compliance of all our lifting anchors with national and European technical requirement has been tested and approved by us.



Spectral analysis



All produced lifting anchors are subject to stringent internal and external quality checks. The extent, type and frequency of production checks carried out are defined by independent supervisory bodies

HALFEN FRIMEDA Lifting anchors are made with strictly regulated raw materials and originate exclusively from our own production facilities or by approved suppliers. All raw materials or finished goods are procured solely from resources that meet our stringent in-house material specifications. Our suppliers must be ISO 9001 certified and must provide complete documentation on the required performance and quality. Therefore, our suppliers have to prove compliance with our material specifications with a 3.1 inspection certificate according to DIN EN 10204.

The inspection of incoming material is not limited to visual examination and dimensional checks. Every consignment is also chemically analysed to ensure the correct chemical content. Moreover, the required tensile strength values, yield stress and rupture points are tested.

Raw material is released for production only if all test results are satisfactory and comply with the provided 3.1-certification. The anchors are continually checked during production for dimensional precision. The required frequency for measurement is set in our quality control procedures.

Each and every batch of anchors is quality checked; all anchors must prove a minimum safety factor against steel failure.



Checking the dimensions of a HALFEN FRIMEDA TPA Anchor

We ensure that the complete process chain, from receipt of the raw material up to final delivery of the finished products, is controllable and traceable. This ensures all our products have the quality that we promise.

We understand the responsibility and will continue to live up to our reputation as supplier of high quality products.



Material procurement — but not at any price

All manufacturers of lifting systems endeavour to offer products at competitive prices, implementing strict cost management and effective raw material procurement to keep production costs low.

Products of this type are often manufactured in low-cost countries as finished articles. However, in applications where safety is important, a cheap product may not always be the best option and it is essential that a guarantee of product quality is also sought.

Any material defect can mask a serious fault. All material composition should be properly traced and production processes continually monitored. Low-cost suppliers may be unable to provide sufficient evidence of quality-controlled production.

Experience shows that a significant number of suppliers, many in so-called low-wage countries, are unable to provide sufficient evidence of acceptable quality-controlled production.

Unmonitored processes can lead to a liability risk!

In our opinion the only way to ensure the required product safety for our lifting anchor products is to regularly check the material used and quality controlled production. Therefore, we source raw materials exclusively from suppliers who can verify and guarantee the stipulated performance, and only supply lifting products that are either manufactured in our own production facilities or by approved suppliers.

As a supplier of lifting anchors we manufacture only to the highest quality standards, to minimise your liability risk.

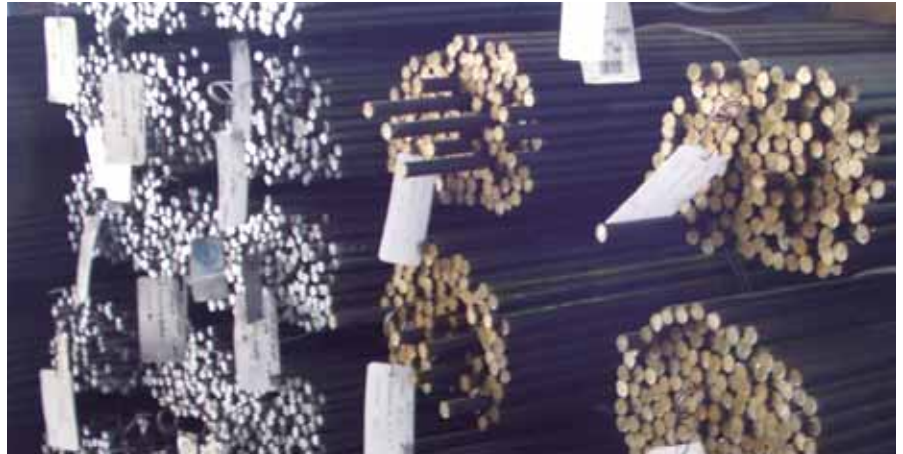

Not the time for experiments

The importance of quality steel for lifting anchors

HALFEN FRIMEDA Lifting anchors are used to lift and move heavy prefabricated concrete elements in precast plants and on construction sites.

It is inevitable that elements sometimes need to be manoeuvred over critical areas and facilities. The failure of an anchor here can have devastating consequences.

Even with correct calculation, deviant material quality can still constitute the critical weak spot. Anchors are subject to further stress especially from dynamic loads (shock factors). Impact strength and elongation at failure are both critical here. Selecting high quality raw material is therefore of the uppermost importance.

Experience is also essential when forging the lifting anchors. Incorrect temper can change the structure in the steel, reducing its load bearing capacity. The standard of quality for HALFEN FRIMEDA Lifting anchors is guaranteed by monitoring incoming raw materials, stringent quality controlled production and final product control; and of course the ISO 9001 certified Quality Management System.

We purchase raw materials exclusively from certified suppliers and manufacture lifting anchors exclusively in our own production facilities according to strict quality requirements.

As a supplier of high quality lifting anchors we help you to minimise your risk.

Summary



The correct metallurgical composition of the steel is the only guarantee of permanent quality e.g. when using anchors at low temperatures and for effects of dynamic shock.

Forging demands proper equipment and a particularly high level of skill to eliminate detrimental, structural changes in steel and to temper forged components effectively.

The accuracy of the forging tools itself is a critical factor; this ensures the lifting anchors fit the lifting devices exactly, enabling the calculated loads to be lifted safely.

HALFEN FRIMEDA LIFTING ANCHOR SYSTEM

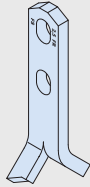
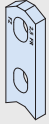
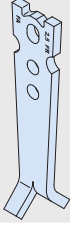
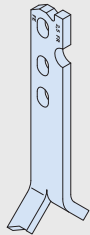
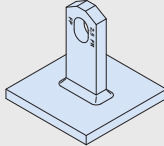
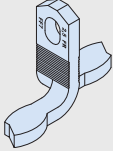
System Overview

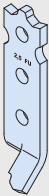
HALFEN FRIMEDA TPA Anchors			
Type	TPA-FS Spread anchor	TPA-FZ Two-hole anchor	TPA-FA Double shoulder anchor
			
Application	Columns, beams, trusses, wall elements, π-slabs	Prestressed concrete trusses, thin-wall elements, low strength concrete (e.g. light-weight concrete)	Thin-wall concrete elements, lifted from a horizontal to a perpendicular position
Parameters	Component thickness, concrete grade, reinforcement	Component thickness, concrete grade, reinforcement	Component thickness, concrete grade, reinforcement
Load class	1,4–22,0	1,4–26,0	1,4–22,0
Information	see page 25–32	see page 33–35	see page 36–38
Type	TPA-FE Single shoulder anchor	TPA-FP Plate anchor	TPA-FF Flat foot anchor
			
Application	Thin-wall concrete elements, lifted from a horizontal to a perpendicular position	Very thin ceiling slabs with surface-embedded anchors	Ceiling slabs with surface-embedded anchors, pipes
Parameters	Component thickness, concrete grade, reinforcement	Component thickness, concrete grade, reinforcement	Component thickness, concrete grade, reinforcement
Load class	1,4–22,0	1,4–10,0	1,4–22,0
Information	see page 34–36	see page 42	see page 40–41
Type	TPA-FD Double-head (column) anchor	TPA-FX Sandwich panel anchor	TPA-FU Universal anchor
			
Application	Columns	Sandwich panels	see TPA-FS, TPA-FZ and TPA-FA
Parameters	Component thickness, concrete grade, reinforcement	Component thickness, concrete grade, reinforcement	Component thickness, concrete grade, reinforcement
Load class	2,5–26,0	2,5–17,0	1,25
Information	see page 45	see page 43–44	see page 39

HALFEN FRIMEDA LIFTING ANCHOR SYSTEM System Overview

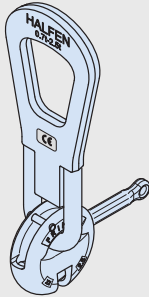
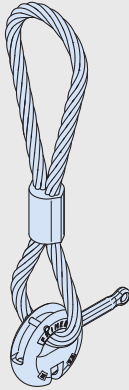
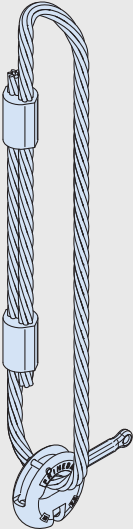
HALFEN FRIMEDA Attachment links			
Type	TPA-R1 Ring clutch	TPA-R2 Ring clutch	TPA-R3 Ring clutch
			
Type	With shackle	With wire cable	With wire cable
Application	For manual release	For manual release	For manual release
Load class	2,5-26,0	1,25-10,0	26,0

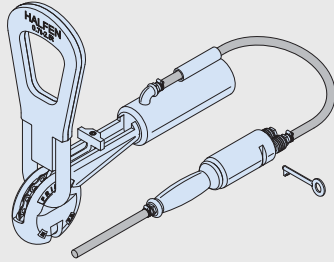
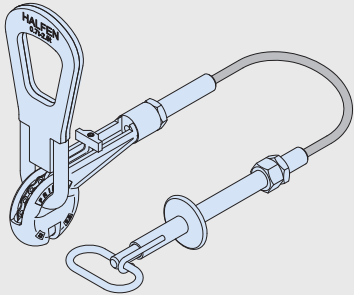
Type	TPA-F1 Ring clutch	TPA-F2 Ring clutch
		
Type	With shackle	With shackle
Application	Pneumatic remote release	Manual remote with bowden cable
Load class	2,5-22,0	2,5-22,0

HALFEN FRIMEDA LIFTING ANCHOR SYSTEM

System Overview

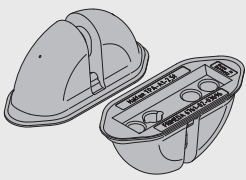
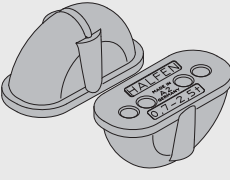
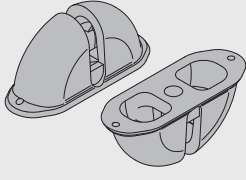
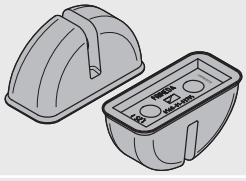
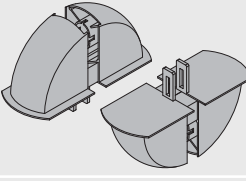
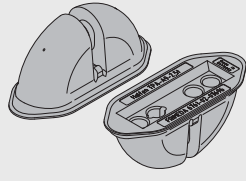
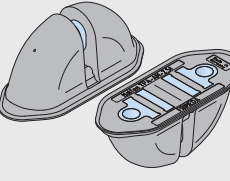
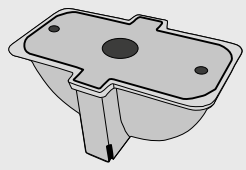
HALFEN FRIMEDA Recess former			
Type	TPA-A-1	TPA-A-2	TPA-A-4
			
Material	Plastic	Rubber	Plastic (hard)
Application	For all anchors except TPA-FU	For TPA-FS, TPA-FZ, TPA-FD, TPA-FP, TPA-FF Anchors	For all anchors except TPA-FU
Installation	H1, H2, HM Holding plates; S1 or S2 Holding bolts	H3 Holding plate	S1 Holding bolt
Features	High durability and good resistance to formwork treatment agents	High durability and good resistance to formwork treatment agents	High durability and good resistance to formwork treatment agents
Load class	2,5–26,0	2,5–10,0	2,5–26,0
Type	TPA-A-7	TPA-A-8	
			
Material	Plastic	Plastic	
Application	For TPA-FU Universal anchor	For anchors of load class 2,5	
Installation	H1 Holding plate, S1 Holding bolt	Two part recess former, pressed together over the anchor head; secured to the formwork with a wedge, pressed between the two fixing tabs	
Features	For especially small recesses, high durability and good resistance to formwork treatment agents	Single-use application	
Load class	1,25	2,5	
Type	TPA-A-9	TPA-AM	TPA-SCFS /-SCFA
			
Material	Plastic	Plastic	Plastic
Application	Specially suitable for TPA-FS, TPA-FZ, TPA-FF and TPA-FD, not suitable for: TPA-FA, TPA-FE, TPA-FU and TPA-FX	For all anchors except TPA-FU	For spread anchors etc. for TPA-FA (SCFA) tilt-up anchor for load class (see below) 0072.150 -00004① 0072.150 -00002 ② -00003 ③ -00005 ④
Installation	H1, H2, HM Holding plates; S1 or S2 Holding bolts	Magnetic	
Features	As for TPA-A-1, but for smooth recesses without protruding concrete	High durability and good resistance to formwork treatment agents	Single-use application
Load class	2,5–26,0	2,5 / 5,0	① 3,0 / 5,0 ② 3,0 ③ 5,0 ④ 7,5

HALFEN FRIMEDA LIFTING ANCHOR SYSTEM

System Overview

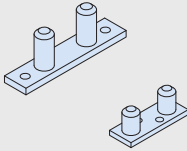
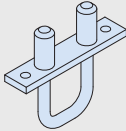
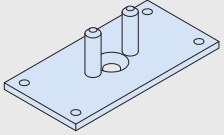
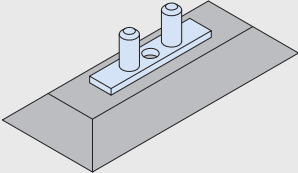
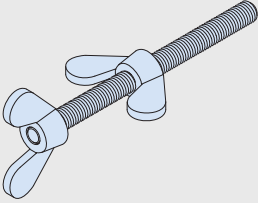
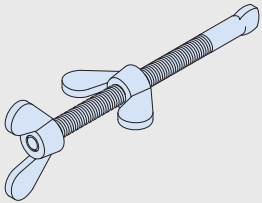
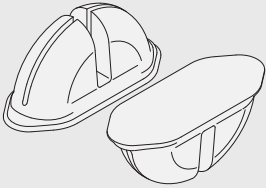
HALFEN FRIMEDA Holding plates and holding bolts			
Type	TPA-H1	TPA-H2	TPA-H3
			
Application	For TPA-A1, TPA-A7 and TPA-A9 Recess formers	For TPA-A1 and TPA-A9 Recess formers	For TPA-A2 Recess formers
Installation	For fixing to formwork	For floating installation	For nailing to formwork
Load class	1,25–26,0	2,5–26,0	2,5–10,0
Type	TPA-HM	TPA-S1 with thread	TPA-S2 Bayonet holding bolt
			
Application	For TPA-A1, TPA-A9 Recess formers to load class 10,0	For TPA-A1, TPA-A7, TPA-A4, TPA-A9, TPA-A2* Recess formers	For TPA-A1, TPA-A9 Recess formers
Installation	For fixing to steel formwork Feature: magnetic	*TPA-A2 only in combination with TPA-H3 Holding plate	
Load class	2,5–10,0	1,25–26,0	2,5–26,0
Type	TPA-V1		
			
Application	To seal recesses for transport, during storage or also as a permanent seal		
Features	Polystyrene		
Installation	Recesses for TPA-A1, TPA-A2, TPA-A4, TPA-A9 and TPA-AM Anchors		
Load class	2,5–10,0		

HALFEN FRIMEDA LIFTING ANCHOR SYSTEM

Product Range TPA Anchors

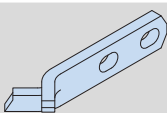
TPA-FS Spread anchor				
Load class				
	Mill finish		Hot-dip galvanized	
	Article number	Order no. 0070.010-	Article number	Order no. 0070.110-
2,5	TPA-FS 1,4-11	00002	TPA-FS 1,4-11 FV	00033
	TPA-FS 1,4-16	00003	-	-
	TPA-FS 2,5-15	00007	TPA-FS 2,5-15 FV	00038
	TPA-FS 2,5-20	00008	TPA-FS 2,5-20 FV	00039
	TPA-FS 2,5-25	00009	TPA-FS 2,5-25 FV	00040
5,0	TPA-FS 5,0-18	00016	TPA-FS 5,0-18 FV	00047
	TPA-FS 5,0-24	00017	TPA-FS 5,0-24 FV	00048
	TPA-FS 5,0-40	00018	TPA-FS 5,0-40 FV	00049
10,0	TPA-FS 7,5-26	00022	TPA-FS 7,5-26 FV	00053
	TPA-FS 7,5-30	00023	TPA-FS 7,5-30 FV	00054
	TPA-FS 7,5-42	00024	TPA-FS 7,5-42 FV	00055
	TPA-FS 10,0-30	00025	TPA-FS 10,0-30 FV	00056
	TPA-FS 10,0-37	00026	TPA-FS 10,0-37 FV	00057
26,0	TPA-FS 10,0-52	00027	TPA-FS 10,0-52 FV	00058
	TPA-FS 14,0-37	00028	TPA-FS 14,0-37 FV	00059
	TPA-FS 14,0-46	00029	TPA-FS 14,0-46 FV	00060
	TPA-FS 22,0-50	00030	TPA-FS 22,0-50 FV	00061
	TPA-FS 22,0-62	00031	TPA-FS 22,0-62 FV	00062

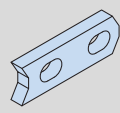
TPA-FZ Two-hole anchor				
Load class				
	Mill finish		Hot-dip galvanized	
	Article number	Order no. 0070.020-	Article number	Order no. 0070.110-
2,5	TPA-FZ 1,4-9	00002	TPA-FZ 1,4- 9 FV	00064
	TPA-FZ 2,5-9	00004	TPA-FZ 2,5- 9 FV	00066
5,0	TPA-FZ 5,0-12	00007	TPA-FZ 5,0-12 FV	00069
10,0	TPA-FZ 7,5-16	00009	TPA-FZ 7,5-16 FV	00071
	TPA-FZ 10,0-17	00010	TPA-FZ 10,0-17 FV	00072
26,0	TPA-FZ 14,0-24	00011	TPA-FZ 14,0-24 FV	00073
	TPA-FZ 22,0-30	00013	TPA-FZ 22,0-30 FV	00075
	TPA-FZ 26,0-30	00012	TPA-FZ 26,0-30 FV	00074

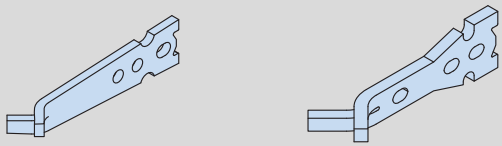
TPA-FA Single shoulder erection anchor (tilt-up)				
Load class				
	Mill finish		Hot-dip galvanized	
	Article number	Order no. 0070.030-	Article number	Order no. 0070.110-
2,5	TPA-FA 1,4-20	00001	TPA-FA 1,4-20 FV	00001
	TPA-FA 2,5-23	00002	TPA-FA 2,5-23 FV	00002
5,0	TPA-FA 5,0-29	00004	TPA-FA 5,0-29 FV	00004
10,0	TPA-FA 7,5-32	00005	TPA-FA 7,5-32 FV	00005
	TPA-FA 10,0-39	00006	TPA-FA 10,0-39 FV	00006
26,0	TPA-FA 12,5-50	00007	TPA-FA 12,5-50 FV	00007
	TPA-FA 17,0-48	00008	TPA-FA 17,0-48 FV	00008
	TPA-FA 22,0-50	00009	TPA-FA 22,0-50 FV	00009
2,5	TPA-FA 2,5-23 A4	00010	Stainless steel A4	
5,0	TPA-FA 5,0-29 A4	00011	Stainless steel A4	

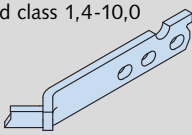
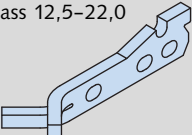
TPA-FE Single shoulder erection anchor (tilt-up)				
Load class	Load class 1,4-10,0		Load class 12,5-22,0	
				
	Mill finish		Hot-dip galvanized	
	Article number	Order no. 0070.040-	Article number	Order no. 0070.110-
2,5	TPA-FE 1,4-20	00001	TPA-FE 1,4-20 FV	00010
	TPA-FE 2,5-23	00002	TPA-FE 2,5-23 FV	00011
5,0	TPA-FE 5,0-29	00004	TPA-FE 5,0-29 FV	00013
10,0	TPA-FE 7,5-32	00005	TPA-FE 7,5-32 FV	00014
	TPA-FE 10,0-39	00006	TPA-FE 10,0-39 FV	00015
26,0	TPA-FE 12,5-50	00007	TPA-FE 12,5-50 FV	00016
	TPA-FE 17,0-48	00008	TPA-FE 17,0-48 FV	00017
	TPA-FE 22,0-50	00009	TPA-FE 22,0-50 FV	00018

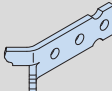
TPA-FU Universal anchor			
Load class			
	Article number	Order no. 0070.100-	Type
1,25	TPA-FU 1,25-12	00001	Mill finish
1,25	TPA-FU 1,25-12 FV	00003	Hot-dip galvanized
1,25	TPA-FU 1,25-12 A2	00002	Stainless steel A2 (W 1.4301)

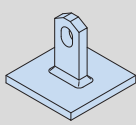

HALFEN FRIMEDA LIFTING ANCHOR SYSTEM Product Range TPA Anchors / Ring Clutches

TPA-FF Flat foot anchor				
Load class				
	Mill finish		Hot-dip galvanized	
	Article number	Order no. 0070.070-	Article number	Order no. 0070.110-
2,5	TPA-FF 1,4-6	00002	TPA-FF 1,4- 6 FV	00020
	TPA-FF 2,5-7	00004	TPA-FF 2,5- 7 FV	00022
5,0	TPA-FF 5,0-12	00007	TPA-FF 5,0-12 FV	00025
10,0	TPA-FF 7,5-17	00009	TPA-FF 7,5-17 FV	00027
	TPA-FF 10,0-20	00010	TPA-FF 10,0-20 FV	00028
26,0	TPA-FF 12,5-22	00011	TPA-FF 12,5-22 FV	00029
	TPA-FF 17,0-27	00012	TPA-FF 17,0-27 FV	00030
	TPA-FF 22,0-31	00013	-	-

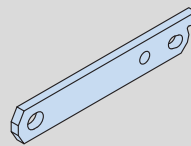
TPA-FP Plate anchor				
Load class				
	Mill finish		Hot-dip galvanized	
	Article number	Order no. 0070.050-	Article number	Order no. 0070.110-
2,5	TPA-FP 1,4- 5	00001	TPA-FP 1,4- 5 FV	00076
	TPA-FP 2,5- 8	00002	TPA-FP 2,5- 8 FV	00077
5,0	TPA-FP 5,0-12	00003	TPA-FP 5,0-12 FV	00078
10,0	TPA-FP 10,0-16	00004	TPA-FP 10,0-16 FV	00079

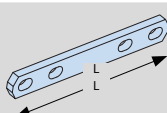

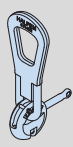
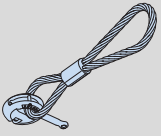
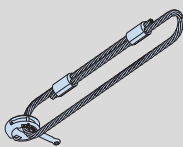
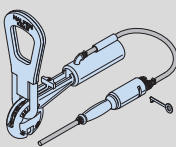
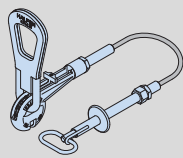
TPA-FX Sandwich panel anchor					
Load class					
	Mill finish		Hot-dip galvanized		
	Article number	Order no. 0070.090-	Article number	Order no. 0070.090-	
2,5	TPA-FX 2,5-25	00001	TPA-FX 2,5-25 FV	00006	
5,0	TPA-FX 5,0-30	00002	TPA-FX 5,0-30 FV	00007	
10,0	TPA-FX 7,5-35	00003	TPA-FX 7,5-35 FV	00008	
	TPA-FX 10,0-35	00004	TPA-FX 10,0-35 FV	00009	
26,0	TPA-FX 17,0-40	00005	TPA-FX 17,0-40 FV	00010	

TPA-FD Double-head (column) anchor					
Load class					
	Mill finish		Hot-dip galvanized		
	Article number	Order no. 0070.089-	Article number	Order no. 0070.089-	
2,5	TPA-FD 2,5 - L-SK	00001	TPA-FD 2,5 - L-SK FV	00002	
5,0	TPA-FD 5,0 - L-SK	00001	TPA-FD 5,0 - L-SK FV	00002	
10,0	TPA-FD 7,5 - L-SK	00001	TPA-FD 7,5 - L-SK FV	00002	
	TPA-FD 10,0 - L-SK	00001	TPA-FD 10,0 - L-SK FV	00002	
26,0	TPA-FD 12,5 - L-SK	00001	TPA-FD 12,5 - L-SK FV	00002	
	TPA-FD 17,0 - L-SK	00001	TPA-FD 17,0 - L-SK FV	00002	
	TPA-FD 22,0 - L-SK	00001	TPA-FD 22,0 - L-SK FV	00002	
	TPA-FD 26,0 - L-SK	00001	TPA-FD 26,0 - L-SK FV	00002	

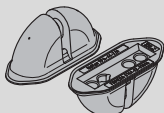

HALFEN FRIMEDA Ring clutches							Ring clutches with remote control release				Replacement part													
Load class	TPA-R1		TPA-R2		TPA-R3		TPA-F1		TPA-F2		TPA-R-E1													
																								
	Article number	Order no. 0071.010-	Article number	Order no. 0071.020-	Article number	Order no. 0071.020-	Article number	Order no. 0071.030-	Article number	Order no. 0071.040-	Article number	Order no. 0071.060-												
1,25	-	-	TPA-R2 1,25	00001	-	-	-	-	-	-	-	TPA-R-E1 1,25-zi	00001											
2,5	TPA-R1 2,5	00001	TPA-R2 2,5	00002	-	-	TPA-F1 2,5	-	TPA-F2 2,5	-	-	TPA-R-E1 2,5-zi	00002											
5,0	TPA-R1 5,0	00002	TPA-R2 5,0	00003	-	-	TPA-F1 5,0	page 55	TPA-F2 5,0	page 57	-	TPA-R-E1 5,0-zi	00003											
10,0	TPA-R1 10,0	00006	TPA-R2 10,0	00006	-	-	TPA-F1 10,0	-	TPA-F2 10,0	-	-	TPA-R-E1 10,0	00004											
22,0	-	-	-	-	-	-	TPA-F1 22,0	-	TPA-F2 22,0	-	-	-	-											
26,0	TPA-R1 26,0	00007	-	-	TPA-R3 26,0	00007	-	-	-	-	-	TPA-R-E1 26,0	00005											

HALFEN FRIMEDA LIFTING ANCHOR SYSTEM

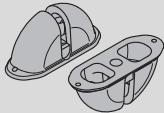
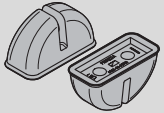
Product Range TPA Recess Formers / Accessories

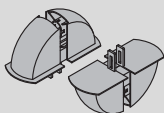
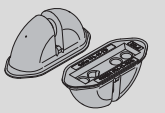
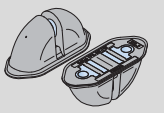
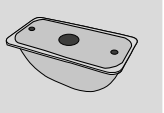
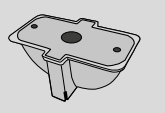
HALFEN FRIMEDA Recess formers									
Load class	TPA-A1		TPA-A2		TPA-A4		TPA-A7		
									
	Article number	Order no. 0072.010-	Article number	Order no. 0072.020-	Article number	Order no. 0072.040-	Article number	Order no. 0072.070-	
1,25	-	-	-	-	-	-	TPA-A7 1,25	00001	
2,5	TPA-A1 2,5	00001	TPA-A2 2,5	00001	TPA-A4 2,5	00001	-	-	
5,0	TPA-A1 5,0	00002	TPA-A2 5,0	00002	TPA-A4 5,0	00002	-	-	
10,0	TPA-A1 10,0	00003	TPA-A2 10,0	00003	TPA-A4 10,0	00003	-	-	
26,0	TPA-A1 26,0	00004	-	-	TPA-A4 26,0	00004	-	-	

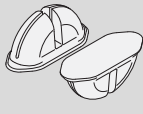
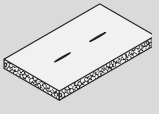
HALFEN FRIMEDA Recess formers										
Load class	TPA-A8		TPA-A9		TPA-AM		TPA-SCFS		TPA-SCFA	
										
	Article number	Order no. 0072.080-	Article number	Order no. 0072.090-	Article number	Order no. 0072.100-	Article number	Order no. 0072.150-	Article number	Order no. 0072.150-
1,25	-	-	-	-	-	-	-	-	-	-
2,5	TPA-A8 2,5	00001	TPA-A9 2,5	00001	TPA-AM 2,5	00001	-	-	-	-
5,0	-	-	TPA-A9 5,0	00002	TPA-AM 5,0	00002	TPA-SCFS 5,0	00004	TPA-SCFA 3,0/5,0	00002/00003
10,0	-	-	TPA-A9 10,0	00003	-	-	-	-	TPA-SCFA 7,5	00005
26,0	-	-	TPA-A9 26,0	00004	-	-	-	-	-	-

Recess filler				Accessories			
Load class	TPA-V1		TPA-A-Z1		TPA-A-E1		
							
	Article number	Order no. 0073.080-	Article number	Order no. 0072.120-	Article number	Order no. 0072.120-	
1,25	-	-	-	-	-	-	
2,5	TPA-V1 2,5	00001	TPA-A-Z1 2,5	00006	TPA-A-E1 2,5	00002	
5,0	TPA-V1 5,0	00002	TPA-A-Z1 5,0	00007	TPA-A-E1 5,0	00003	
10,0	TPA-V1 10,0	00003	TPA-A-Z1 10,0	00008	TPA-A-E1 10,0	00004	
26,0	-	-	TPA-A-Z1 26,0	00009	TPA-A-E1 26,0	00005	

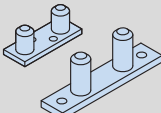
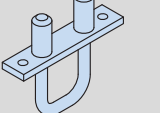
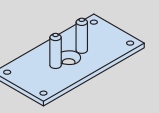
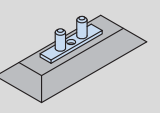
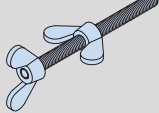
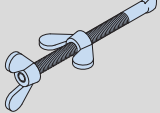
HALFEN FRIMEDA Holding plates								HALFEN FRIMEDA Retaining bolts				
Load class	TPA-H1		TPA-H2		TPA-H3		TPA-HM		TPA-S1		TPA-S2	
												
	Article number	Order no. 0073.010-	Article number	Order no. 0073.020-	Article number	Order no. 0073.030-	Article number	Order no. 0073.050-	Article number	Order no. 0073.060-	Article number	Order no. 0073.070-
1,25	TPA-H1 1,25	00001	-	-	-	-	-	-	-	-	-	
2,5	TPA-H1 2,5	00002	TPA-H2 2,5	00001	TPA-H3 2,5	00001	TPA-HM 2,5	00001	TPA-S1-M 8	00001	-	-
5,0	TPA-H1 5,0	00003	TPA-H2 5,0	00002	TPA-H3 5,0	00002	TPA-HM 5,0	00002		TPA-S2-M 8	00001	
10,0	TPA-H1 10,0	00004	TPA-H2 10,0	00003	TPA-H3 10,0	00003	TPA-HM 10,0	00003		TPA-S1-M12	00002	TPA-S2-M12
26,0	TPA-H1 26,0	00005	TPA-H2 26,0	00004	-	-	-	-	TPA-S1-M16	00003	-	-

HALFEN FRIMEDA LIFTING ANCHOR SYSTEM

Installation and Application

Safety regulations

A transport anchor system consists of the permanently cast-in transport anchor and the temporarily connected lifting equipment.

The basic principles for dimensioning and application of transport anchors can be found in EN 13155.

The regulations require the following safety factors:

Failure safety factors	
Steel failure of anchors:	$\gamma = 3.0$
Concrete failure*:	$\gamma = 2.5$
Failure in the lifting-link:	$\gamma = 4.0$

* A safety factor of $\gamma = 2.3$ can be assumed for transport anchors in precast elements installed in a continuously supervised factory environment.



To ensure safety, these installation and application instructions for HALFEN FRIMEDA Lifting systems must always be available at the place of use.

The installation and application instructions must be readily available on site, in the precast plant or on the construction site. The plant or site manager must ensure that the operator has read and understood the installation and application instructions for this system.

Identification

All HALFEN FRIMEDA Lifting and hoisting equipment are clearly and visibly marked. According to EN 13155 safety regulations for lifting anchors and systems, identification marking of all lifting elements must remain clearly visible, even after installation.

Identification on the anchor

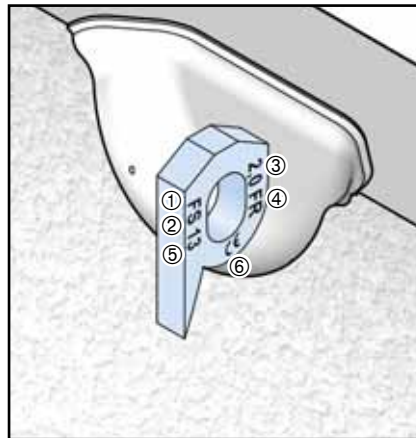

① System type

② Anchor type

- S = Spread anchor
- Z = Two-hole anchor
- P = Plate anchor
- A = Erection anchor (tilt-up)
- E = One-sided erection anchor (tilt-up)
- F = Flat foot anchor
- D = Double-head (column) anchor
- X = Sandwich panel anchor
- U = Universal anchor

③ Load class

④ Manufacturer's identification

⑤ Anchor length

⑥ CE marking

Installation and application

The following technical specifications and requirements must be observed when installing HALFEN FRIMEDA Lifting anchor systems.

Damaged anchor

Transport anchors that are incorrectly installed, defective or damaged (for example corrosion damage or with visible deformities) must not be used for lifting.

Stainless steel transport anchors

Transport anchors may not be used repeatedly. Multiple lifting in the normal sequence of transporting and loading through to final installation is not regarded as repeated use. Transport anchors for permanent use in crane ballast etc. must be manufactured in accordance with EN 1993-1-4.

Quality control

All required in-house quality control has been observed for transport anchors and systems in accordance with ISO 9001.

HALFEN FRIMEDA LIFTING ANCHOR SYSTEM

Installation and Application

Criteria for anchor selection

Maximum load capacities, edge distances and installation values can be found in the respective tables. Irrespective of the selected anchor-type (selected according to the load acting on the anchor) the following factors must be taken into account for calculation:

- › weight of the precast element
- › number of anchors
- › anchor layout
- › number of load bearing anchor
- › spread angle in the hoist
- › diagonal pull properties of the anchor
- › dynamic loads
- › adhesion to the formwork

Install an erection (tilt-up) anchor and ensure sufficient reinforcement if slabs are cast in the horizontal and subsequently lifted upright without using a tilting-table.

Number of anchors

The number of anchors determines the type of hoist that needs to be used. A hoist with more than two cables is statically indeterminate if the anchors are aligned along a single axis. Hoists with more than three cables are deemed statically indeterminate if measures are not taken to ensure the load is distributed amongst all anchors (for example; with a spreader beam etc.).

Installation and application

HALFEN FRIMEDA Lifting anchor systems should only be installed when the following technical specifications and requirements have been determined:

- › load capacity
- › edge spacing
- › concrete grade
- › load directions
- › additional reinforcement

Load capacity

The load capacity of the anchor depends on:

- › concrete compression strength f_{ci} at time of lift (cube-test $15 \times 15 \times 15$ cm)
- › anchorage length of the anchor
- › edge and axial anchor-spacing
- › load direction
- › reinforcement layout

Calculating the tension load

The tension force Z in the anchor is generally calculated using the following formulae:

Load case: removing the formwork

$$F_Z = F_G \times z \times \xi / n$$

or

$$F_Z = (F_G + q_{adh} \times A_f) \times z / n$$

Load case: transport

$$F_Z = F_G \times z \times \psi_{dyn} / n$$

Abbreviations:

F_Z = tension force on the anchor [kN]

F_G = element weight [kN]
(according to EN 1991-1-1
specific weight of $\gamma = 25$ kN/m³)

A_f = contact surface between the
concrete and formwork [m²]

n = number of load-bearing anchors

z = spread angle factor

ξ = formwork adhesion factor

ψ_{dyn} = dynamic factor

q_{adh} = base value for formwork adhesion

F_{adh} = effective load caused by
formwork adhesion [kN]

HALFEN FRIMEDA LIFTING ANCHOR SYSTEM

Installation and Application

Loads at the anchor – Dead weight

Element weight is defined as: Volume of the element × specific weight of the concrete

Increase factors:

1. Spread angle

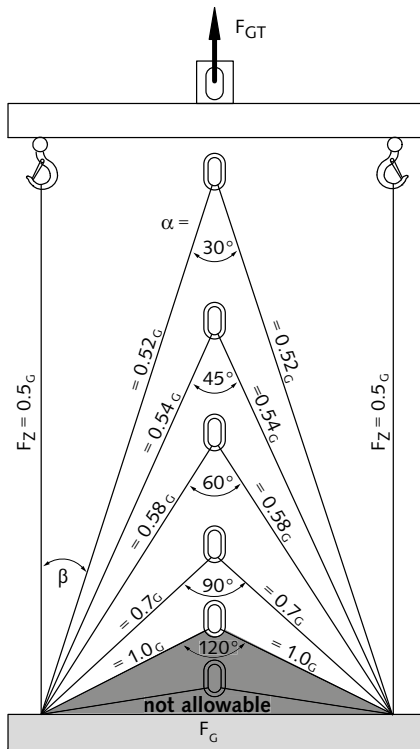

Spread angle factors		
Cable angle	Spread angle	Factor
β	α	z
0°	-	1.00
7.5°	15°	1.01
15°	30°	1.04
22.5°	45°	1.08
30°	60°	1.16
37.5°	75°	1.26
45°	90°	1.41
52.5°	105°	1.64
60.0°	120.0°	2.00

2. Dynamic loads

The effect of dynamic loading depends mainly on the lifting equipment between the crane and the load lifting head.

Cables made of steel or synthetic fibres have a damping effect. With increasing cable length the damping effect is increased.

However short chains have an unfavourable effect. The forces acting on the lifting anchors are calculated taking the shock factor ψ_{dyn} into account.

Dynamic factors ψ_{dyn}^*	
Lifting unit	shock factor ψ_{dyn}^*
Stationary crane, swing-boom crane, rail crane	1.3
Lifting and moving on level terrain	2.5
Lifting and moving on uneven terrain	≥ 4.00

*If other values from reliable tests or through proven experience are available for ψ_{dyn} then these may be used for calculation.

For other non-listed transport and lifting situations the coefficient ψ_{dyn} is defined through tests or empirical values.

3. Non-symmetrical anchor layout

The load in each anchor is calculated using bar statics if the anchors are not installed symmetrically to the load's centre of gravity.

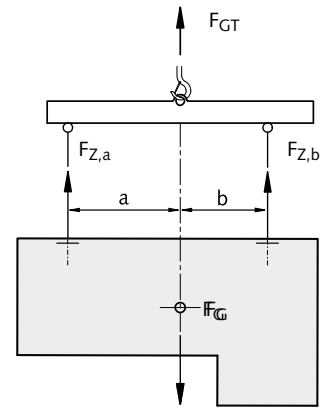

Figure: Uneven loading of the anchor caused by non-symmetrical installed anchors in respect to the centre of gravity of the load.

The load's centre of gravity will always stabilize vertically under the crane hook. Load distribution in non-symmetrical installed anchors when using a spreader beam is calculated as below:

$$F_{Z,a} = F_G \times b / (a + b)$$

$$F_{Z,b} = F_G \times a / (a + b)$$



Note: To avoid precast elements hanging at a slant when being moved, the hook in the spreader beam should be directly above the centre of gravity. The transport anchors should be installed symmetrically to the centre of gravity, when lifting elements without a spreader beam.

HALFEN FRIMEDA LIFTING ANCHOR SYSTEM

Installation and Application

Total load on the anchor – Formwork adhesion

Adhesion:

1. Adhesion forces

Depending on the material used for the formwork the adhesion between formwork and concrete can vary.

The following table can be used as a reference:

Adhesion to the formwork	
Lubricated steel formwork	$q_{adh} \geq 1 \text{ kN/m}^2$
Painted timber formwork	$q_{adh} \geq 2 \text{ kN/m}^2$
Rough formwork	$q_{adh} \geq 3 \text{ kN/m}^2$

The adhesion value (F_{adh}) for formwork is calculated using the following equation:

$$F_{adh} = q_{adh} \times A_f \text{ ①}$$

① Surface of the prefabricated concrete element in contact with the formwork prior to lifting.

2. Increased adhesion

Increased adhesion to the formwork must be assumed for π -panel and coffered ceiling slabs.

To simplify calculation, a multiple of the mass is used:

Increased adhesion to the formwork	
π - panel	$\xi = 2$
Ribbed panel	$\xi = 3$
Waffled panel	$\xi = 4$

Substantial load increase can also be encountered when components are lifted parallel or near parallel to parts of the formwork. This applies to ribbed slabs and coffered ceiling slabs and can also apply to vertically cast columns and slabs.

3. Striking the formwork

Adhesion to the formwork should be minimised before lifting by removing as many parts of the formwork as possible.

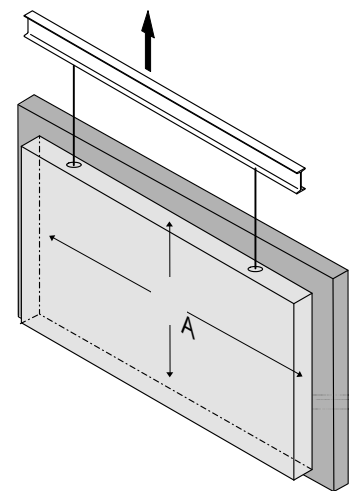

To reduce forces caused by adhesion and friction – especially when lifting from tilt-up tables – we recommend removing the formwork from the concrete elements before lifting (e.g. short vibration of the tilt-up table or using wedges).

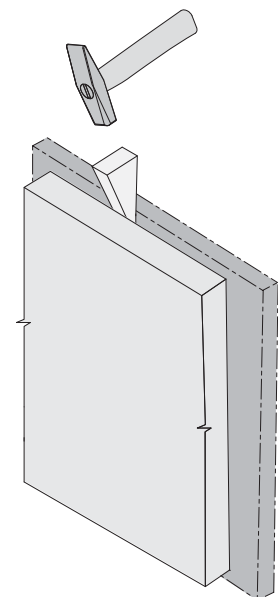

HALFEN FRIMEDA LIFTING ANCHOR SYSTEM

Installation and Application

Tensile loads at the anchors

Axial load β : 0° to 10°

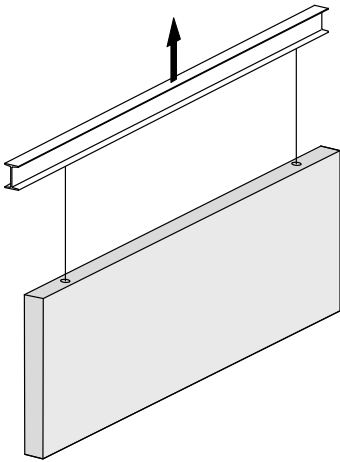

Diagonal load β : 10° to 60° ①

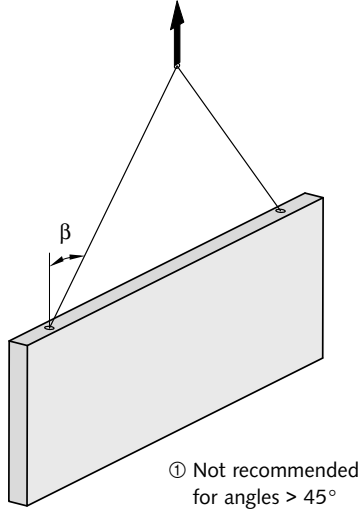

Tilt-up γ : 90°

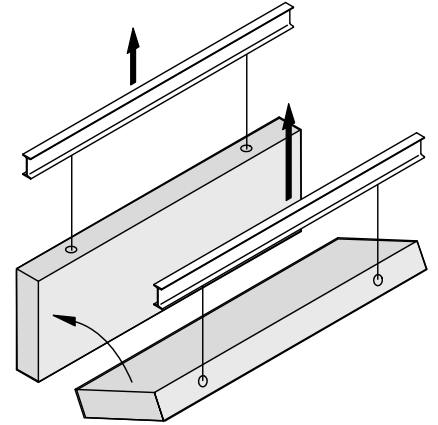

Additional shear reinforcement can be omitted when using a tilting table and a load angle of $\gamma < 15^\circ$.

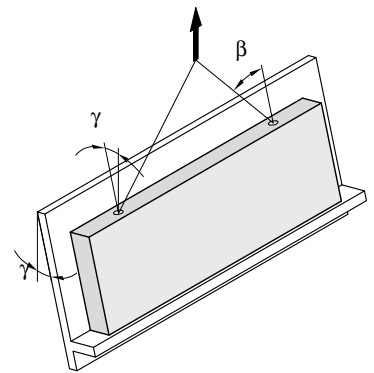

Static system

Position of anchors in walls

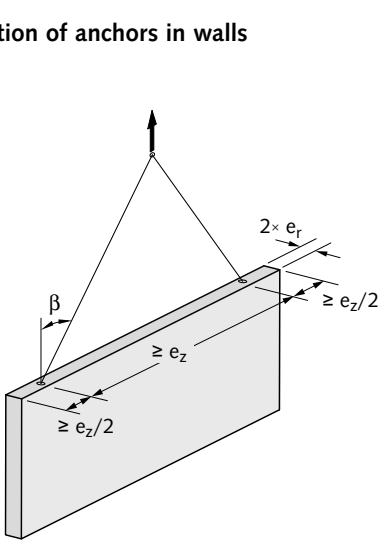

Assumed number of load bearing anchors: $n = 2$

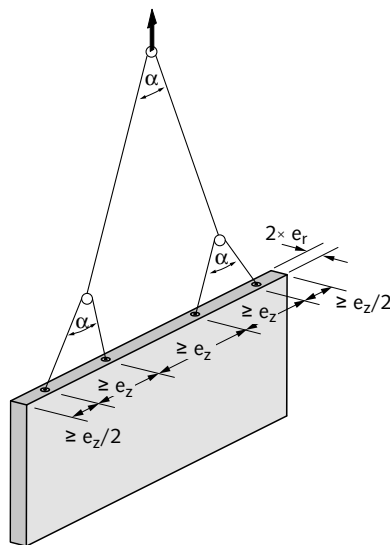

Assumed number of load bearing anchors: $n = 4$

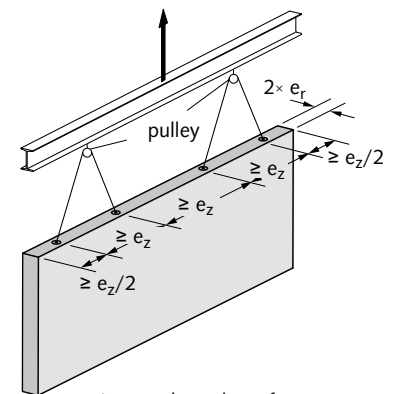

Assumed number of load bearing anchors: $n = 4$

HALFEN FRIMEDA LIFTING ANCHOR SYSTEM

Installation and Application

Static systems

Layout of the anchors in slabs

A beam with more than two suspension points or a panel with more than three suspension points are assumed to be statically indeterminate even if the anchors are arranged symmetrically to the centre of load.

Due to unavoidable tolerances in suspension systems and in the position of the anchors, it can never be determined whether the load is distributed equally amongst all anchors.

Using tolerance-compensating suspension systems permit exact load distribution (e.g. articulated lifting beam combinations, multiple slings with compensating rig, etc.).

This type of system should only be used by experienced specialists; also bear in mind that this system must be used in the precast plant and on the construction site. If in doubt assume only two anchors are load bearing (BGR 500 Ch. 2.8 / section 3.5.3).

The use of two anchors is recommended for beams and upright panels, and four anchors installed symmetrically to the load centre is recommended for horizontal slabs. In both instances, it can be assumed that two anchors will be bearing equal loads.

Examples

Using three anchors ensures a static determinate system.

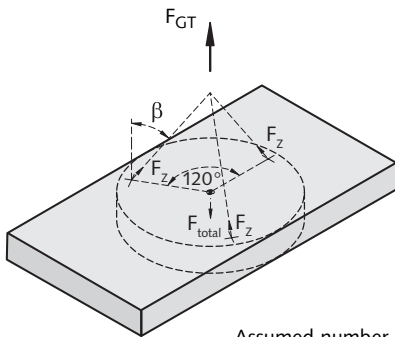

Assumed number of load-bearing anchors: $n = 3$

With four independent cable runs or two single diagonal cables, only two anchors can be assumed to be load-bearing.

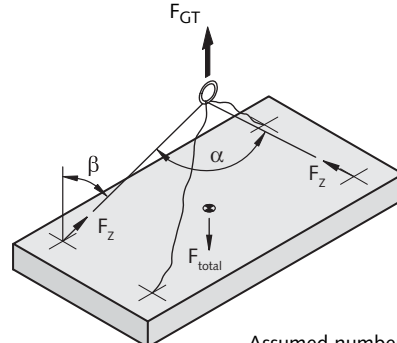

Assumed number of load-bearing anchors: $n = 2$

Perfect static weight distribution is achieved by using a spreader beam and two symmetrical pairs of anchors.

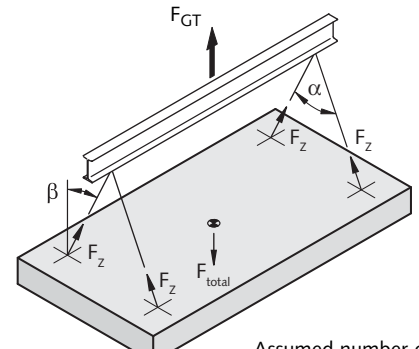

Assumed number of load-bearing anchors: $n = 4$

As the anchors are arranged asymmetrically, only two anchors can be assumed to be load-bearing.

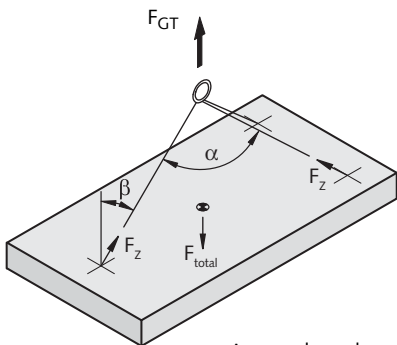

Assumed number of load-bearing anchors: $n = 2$

The system with compensating rig makes it possible to distribute the load evenly over 4 anchors.

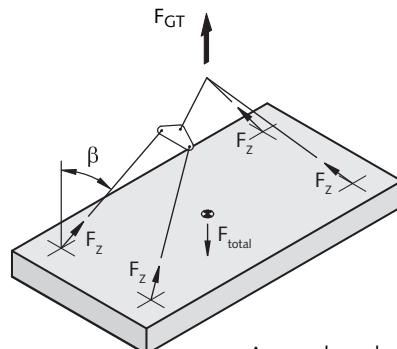

Assumed number of load-bearing anchors: $n = 4$

Perfect static weight distribution can be achieved using a spreader beam. This avoids diagonal pull.

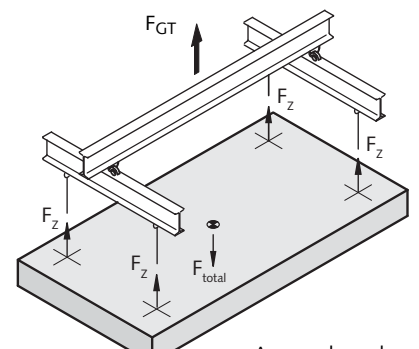

Assumed number of load-bearing anchors: $n = 4$

HALFEN FRIMEDA LIFTING ANCHOR SYSTEM

Installation and Application

Anchor installation and application – Static system

Transport anchors are made out of killed steel with a high notch toughness, which retains its safe load capacity under shock load in temperatures as low as minus 20°C. Transport anchor production is ISO 9001 certified and is subjected to continual monitoring.

The HALFEN FRIMEDA Lifting anchor is cast in with the recess former attached. After the concrete has set, the recess former is removed. The ring clutch can then be attached to the transport anchor.

The connection meets all work regulation safety requirements; the transport anchor is in a recess so there are no dangerous protruding elements in the finished precast elements.

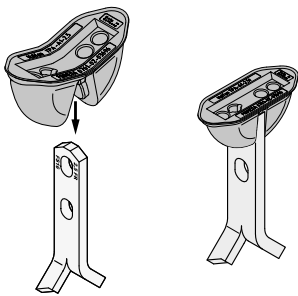

Installation of the A1 Recess former

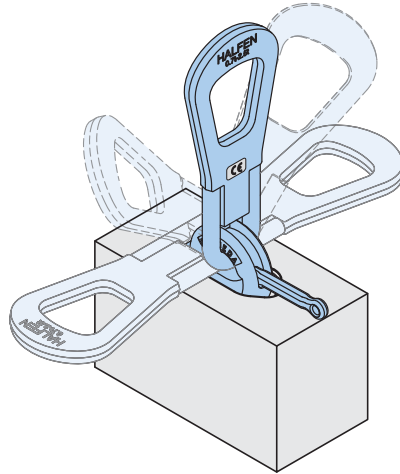
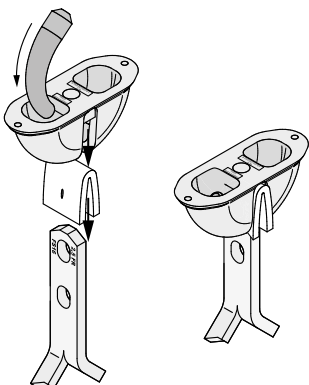

Cast-in anchor: multi-directional lift

Combining accessories and anchors	
Ring clutch load class	Anchor load class
1,25	1,25
2,5	1,4 2,5
5,0	5,0
10,0	7,5 10,0
26,0	12,5
	14,0
	17,0
	22,0
	26,0

The HALFEN product range with its wide selection of lifting anchors in various load classes and lengths guarantees the required technically, correct solution is available for nearly every shape of precast reinforced concrete element. Cost-efficient for conventional building projects (beams, ceiling slabs, trusses, columns and stairs) and for utility and excavation projects (pipes and shafts).

Advantages:

Safety is the top priority when moving or transporting precast elements. The cast-in forged steel spherical head transport anchors have large safety factors against steel and concrete failure. The load class is clearly marked on all anchors. On some anchors the length is also marked.

The comprehensive product range including anchors and numerous system accessories allows the most economical solution for every precast element; regardless of shape.

- There is no risk of mix-ups in a particular load class.
- The lifting link (the ring clutch) is wear resistant even in the toughest construction situations.
- The system ensures fast anchor installation in precast elements and due to the special anchor shape the crane hook is connected within seconds to the precast element.
- Anchor installation in the precast plant using the system accessories is remarkably easy.
- Engaging and disengaging the universal lifting link – fitted to a crane-cable – with the transport anchor is easy and can be done using one hand.
- Thanks to efficient production methods and its proven design HALFEN FRIMEDA Lifting anchors are exceptionally economical.

HALFEN FRIMEDA LIFTING ANCHOR SYSTEM

Basic Principles for Load Capacities

Spread anchors for large surface precast elements

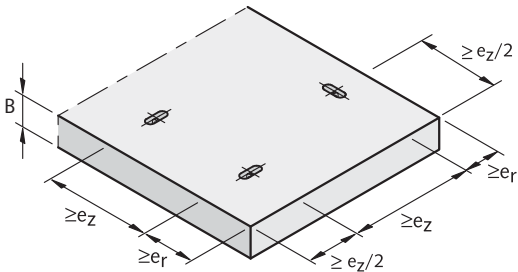

Spread anchors for thin-wall precast unit

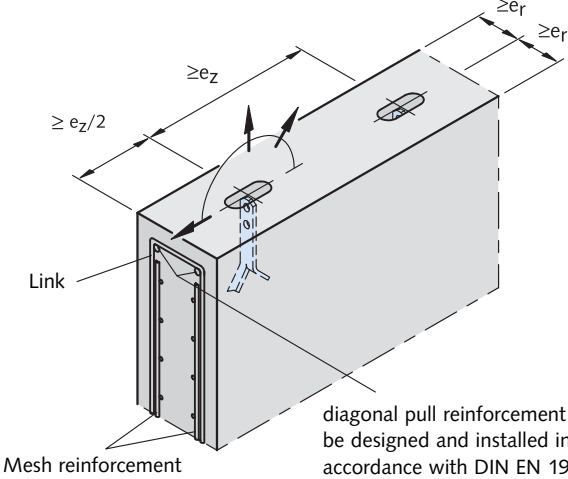

diagonal pull reinforcement must be designed and installed in accordance with DIN EN 1992 for load directed towards a small edge (face end)

Minimum thickness of precast elements

$$B = l + k + c$$

- l = Anchor length
- k = Cover; anchor head
- c = Concrete cover acc. to DIN EN 1992

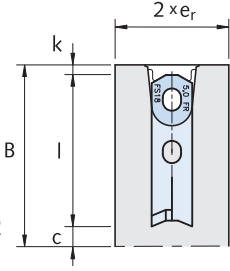

Basic principles of the load capacity tables

The values for loads and edge distances in the following tables have been calculated in accordance with the applicable regulations and a calculation process modified for anchors or established through tests.

Anchor arrangement for thin-wall elements

Spread, tilt-up and two-hole anchors may only be installed in **thin-wall elements** with the flat steel at right-angles to the slab.

Symbols used in this catalogue	
Load direction	Symbol
Central pull in direction of anchor axis	
Transverse pull perpendicular to the anchor surface	
Transverse pull parallel to the anchor surface	
Diagonal pull, transverse component perpendicular to the anchor surface	
Diagonal pull, transverse component parallel to the anchor surface	

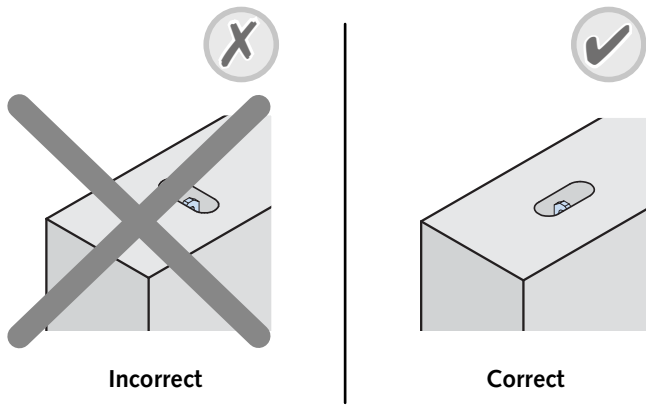

HALFEN FRIMEDA LIFTING ANCHOR SYSTEM

TPA-FS Spread Anchor

Anchor dimensions

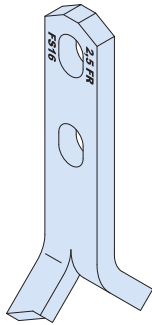

The spread anchor with additional slot is very versatile. It provides efficient anchorage in both thin panels and large surface slabs. For special requirements and very thin walls the spread anchor can also be used as a two-hole anchor.

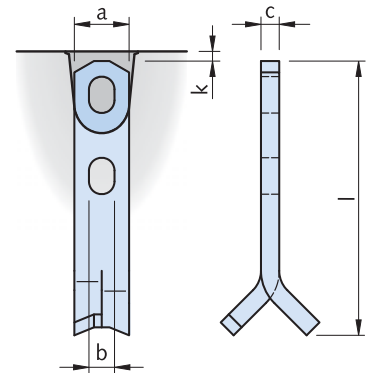

Dimensions TPA-FS Spread anchor

Load class lifting link	Article number Mill finish	Order no. 0070.010-	Article number Hot-dip galvanized	Order no. 0070.110-	a [mm]	b [mm]	c [mm]	l [mm]	k [mm]
2,5	TPA-FS 1,4-11	00002	TPA-FS 1,4-11 FV	00033	30	14	6	110	10
	TPA-FS 1,4-16	00003	-	-	30	14	6	160	
	TPA-FS 2,5-15	00007	TPA-FS 2,5-15 FV	00038	30	14	10	150	
	TPA-FS 2,5-20	00008	TPA-FS 2,5-20 FV	00039	30	14	10	200	
	TPA-FS 2,5-25	00009	TPA-FS 2,5-25 FV	00040	30	14	10	250	
5,0	TPA-FS 5,0-18	00016	TPA-FS 5,0-18 FV	00047	40	18	15	180	10
	TPA-FS 5,0-24	00017	TPA-FS 5,0-24 FV	00048	40	18	15	240	
	TPA-FS 5,0-40	00018	TPA-FS 5,0-40 FV	00049	40	18	15	400	
10,0	TPA-FS 7,5-26	00022	TPA-FS 7,5-26 FV	00053	60	26	16	260	15
	TPA-FS 7,5-30	00023	TPA-FS 7,5-30 FV	00054	60	26	16	300	
	TPA-FS 7,5-42	00024	TPA-FS 7,5-42 FV	00055	60	26	16	420	
	TPA-FS 10,0-30	00025	TPA-FS 10,0-30 FV	00056	60	26	20	300	
	TPA-FS 10,0-37	00026	TPA-FS 10,0-37 FV	00057	60	26	20	370	
	TPA-FS 10,0-52	00027	TPA-FS 10,0-52 FV	00058	60	26	20	520	
26,0	TPA-FS 14,0-37	00028	TPA-FS 14,0-37 FV	00059	80	35	20	370	15
	TPA-FS 14,0-46	00029	TPA-FS 14,0-46 FV	00060	80	35	20	460	
	TPA-FS 22,0-50	00030	TPA-FS 22,0-50 FV	00062	90	35	28	500	
	TPA-FS 22,0-62	00031	TPA-FS 22,0-62 FV	00063	90	35	28	620	

Technical basics

- Observe the minimum edge distance ($ez/2$) for the spherical head anchor.
- Elements must be designed for load case "transport".
- Horizontally cast element must be removed from the tilt-up table near vertical at an angle $\geq 75^\circ$, otherwise the load case is "pitching".
- Reducing the reinforcement is possible if the anchor is not subjected to maximum possible load or if other measures are taken.
- Present, required reinforcement can be assumed as contributing towards the minimal required reinforcement for the transport anchor.
- Constructive measures may be taken to lower the edge distance (reinforcement).

HALFEN FRIMEDA LIFTING ANCHOR SYSTEM

TPA-FS Spread Anchor

Reinforcement near the anchor in thin-wall precast elements

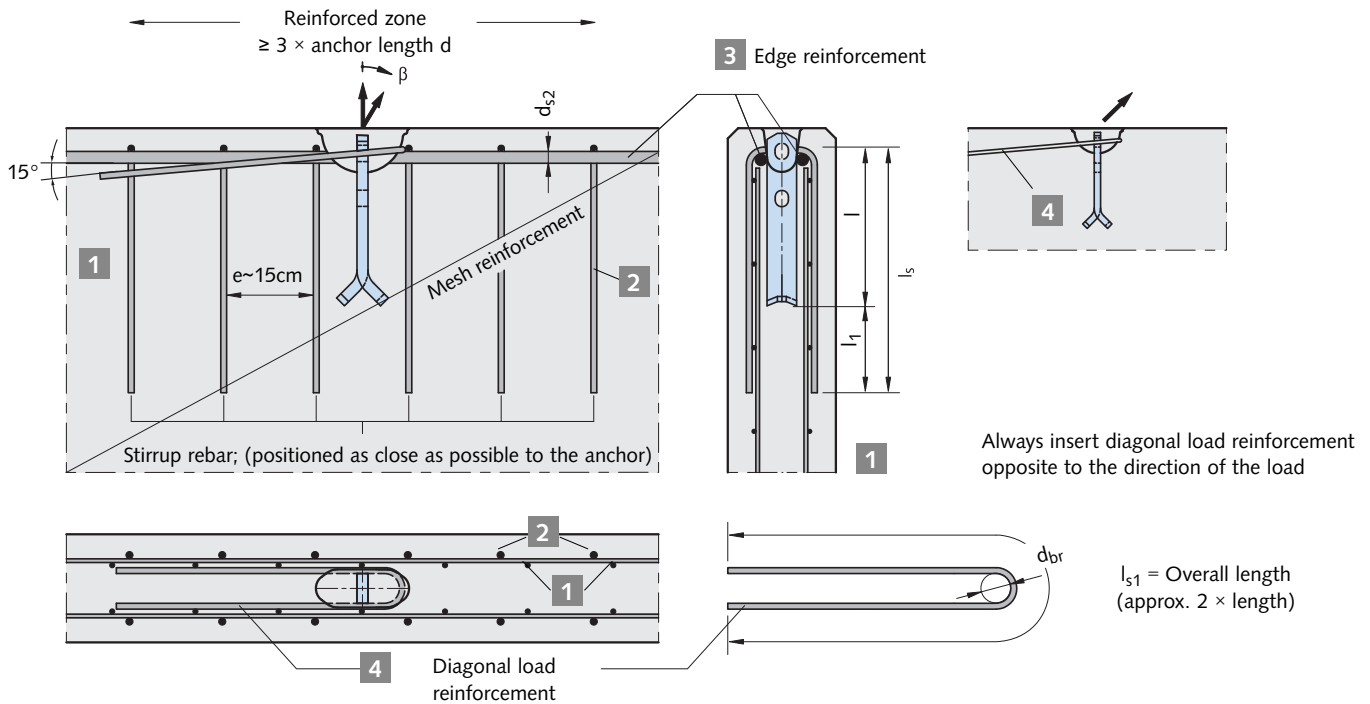

The diagonal load reinforcement must be placed as close as possible under the recess former and installed with full contact to the anchor.

A bend radius according to DIN EN 1992 is not mandatory for the diagonal stirrup.

Reinforcement of thin precast concrete elements

Load class lifting links	Load class anchor	1	2			3	4		
		Mesh reinforcement both sides, crosswise Pull ($\beta \leq 30^\circ$) [mm ² /m]	number	U-bar B500B Diagonal load ($\beta > 30^\circ$) d_s [mm]	l_1 [mm]	Edge reinforcement B500B d_{s2} [mm]	Diagonal pull reinforcement B500B d_{s1} [mm]	$d_{br,min}$ [mm]	l_{s1}
2,5	1,4	2 × 131	4	∅ 6	400	∅ 8	∅ 6	47	900
	2,5		4	∅ 8	600	∅ 10	∅ 8	47	1200
5,0	5,0	2 × 131	4	∅ 10	800	∅ 12	∅ 12	53	1550
10,0	7,5	2 × 188	4	∅ 10	800	∅ 12	∅ 14	71	2000
	10,0		6	∅ 10	1000	∅ 14	∅ 16	71	2300
26,0	14,0	2 × 377	8	∅ 10	1000	∅ 14	∅ 20	116	2600
	22,0		8	∅ 10	1200	∅ 16	∅ 28	116	3450

① $l_s = l_1 + \text{Anchor length } l$
When using short anchors and a high minimum number of stirrup their spacing has to be less than 15 cm.

② **No diagonal pull reinforcement is needed for concrete strength of:**
 - β_w 15 N/mm² + 3-times minimum element thickness
 - β_w 25 N/mm² + 2.5-times minimum element thickness
 - β_w 35 N/mm² + 2-times minimum element thickness

HALFEN FRIMEDA LIFTING ANCHOR SYSTEM

TPA-FS Spread Anchor

Spread anchors in slabs

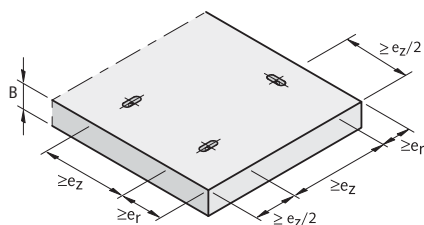

The spread anchors can be used in slab-type elements. Specified edge and axial anchor spacings must be observed.



Required reinforcement **1**, reinforcement **4** only with diagonal pull. → see table on page 26 "Reinforcement of thin precast concrete elements".

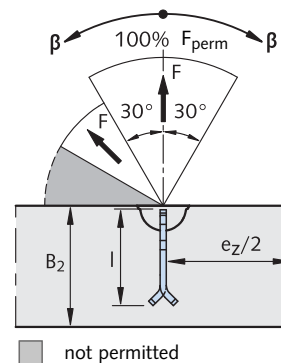

TPA-FS Spread anchor in slabs: Load capacities and installation dimensions

Load class lifting link	Article number	Anchor length l [mm]	Minimum element thickness B ₂ [mm]	Load capacities with f _{ci} * ≥ 15 N/mm ²		Minimum edge distances / slabs e _r			Minimum axial anchor spacing e _z [mm]
				Axial pull [kN]	Diagonal pull [kN]	with β _w ≥ 15 N/mm ² [mm]	with β _w ≥ 25 N/mm ² [mm]	with β _w ≥ 35 N/mm ² [mm]	
2,5	TPA-FS 1,4 - 11	110	145	14.0	11.2	70	50	40	380
	TPA-FS 1,4 - 16	160	195	14.0	11.2	50	35	35	530
	TPA-FS 2,5 - 15	150	185	25.0	20.0	120	85	70	520
	TPA-FS 2,5 - 20	200	235	25.0	20.0	90	65	50	720
	TPA-FS 2,5 - 25	250	285	25.0	20.0	75	50	40	920
5,0	TPA-FS 5,0 - 18	180	215	50.0	40.0	260	180	145	600
	TPA-FS 5,0 - 24	240	275	50.0	40.0	195	140	110	840
	TPA-FS 5,0 - 40	400	435	50.0	40.0	115	85	65	1480
10,0	TPA-FS 7,5 - 26	260	300	75.0	60.0	300	215	175	900
	TPA-FS 7,5 - 30	300	340	75.0	60.0	265	190	150	1060
	TPA-FS 7,5 - 42	420	460	75.0	60.0	190	135	110	1540
	TPA-FS 10,0 - 30	300	340	100.0	80.0	390	275	220	1030
	TPA-FS 10,0 - 37	370	410	100.0	80.0	315	225	180	1310
	TPA-FS 10,0 - 52	520	560	100.0	80.0	225	160	130	1910
26,0	TPA-FS 14,0 - 37	370	410	140.0	112.0	500	355	285	1230
	TPA-FS 14,0 - 46	460	500	140.0	112.0	400	285	230	1590
	TPA-FS 22,0 - 50	500	540	220.0	176.0	675	480	385	1700
	TPA-FS 22,0 - 62	620	660	220.0	176.0	540	385	310	2180

- Required reinforcement: minimum standard reinforcement
- The concrete cover for the anchor foot is 25mm. Slab thicknesses < B₂ are only possible with suitable corrosion protection.
- The upper reinforcement must be dimensioned for load case "transport".

*f_{ci} = cube concrete strength at time of lifting

HALFEN FRIMEDA LIFTING ANCHOR SYSTEM

TPA-FS Spread Anchor – no Special Requirements on the Reinforcement

Load capacities of HALFEN FRIMEDA Lifting anchors in beams and walls – no special reinforcement requirements

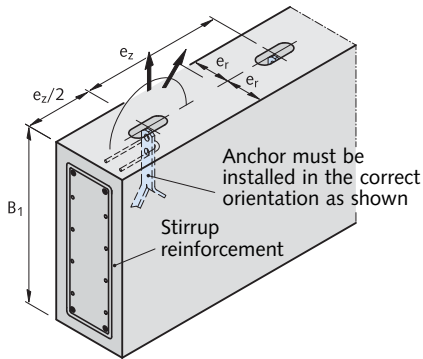

Required reinforcement:

1, **4*** → see table on page 26
"Reinforcement of thin precast concrete elements".

*reinforcement **4** only with diagonal pull

Spread anchors in beams and walls – no special reinforcement requirements (load class 2,5–5,0)

Load class lifting links	Article number	Anchor length l [mm]	Min. height of beams B ₁ [mm]	Wall thickness 2 × e _r [mm]	Load capacity [kN] at concrete strength f _{ci} for				Axial spacing of anchors e _z [mm]
					Axial pull up to 30° [β]	Diagonal pull up to 60° [β]	Axial pull and diagonal pull up to 60° [β]	Axial pull and diagonal pull up to 60° [β]	
					15 N/mm ²	15 N/mm ²	25 N/mm ²	35 N/mm ²	
2,5	TPA-FS 1,4 - 11	110	240	80	11.5	9.2	14.0	14.0	380
	TPA-FS 1,4 - 11	110	240	100	13.6	10.9	14.0	14.0	380
	TPA-FS 1,4 - 11	110	240	120	14.0	12.5	14.0	14.0	380
	TPA-FS 1,4 - 16	160	340	70	13.2	11.4	14.0	14.0	530
	TPA-FS 1,4 - 16	160	340	80	14.0	12.6	14.0	14.0	530
	TPA-FS 1,4 - 16	160	340	100	14.0	14.0	14.0	14.0	530
	TPA-FS 2,5 - 15	150	320	120	19.8	15.9	25.0	25.0	520
	TPA-FS 2,5 - 15	150	320	150	23.4	18.8	25.0	25.0	520
	TPA-FS 2,5 - 15	150	320	180	25.0	21.5	25.0	25.0	520
	TPA-FS 2,5 - 20	200	420	100	20.5	17.7	25.0	25.0	720
	TPA-FS 2,5 - 20	200	420	120	24.6	20.3	25.0	25.0	720
	TPA-FS 2,5 - 20	200	420	150	25.0	24.0	25.0	25.0	720
	TPA-FS 2,5 - 25	250	520	100	20.6	20.6	25.0	25.0	920
	TPA-FS 2,5 - 25	250	520	120	24.7	24.7	25.0	25.0	920
TPA-FS 2,5 - 25	250	520	140	25.0	25.0	25.0	25.0	920	
5,0	TPA-FS 5,0 - 18	180	380	240	37.8	30.2	48.8	50.0	600
	TPA-FS 5,0 - 18	180	380	300	44.7	35.7	50.0	50.0	600
	TPA-FS 5,0 - 18	180	380	400	50.0	44.3	50.0	50.0	600
	TPA-FS 5,0 - 24	240	500	200	42.3	33.9	50.0	50.0	840
	TPA-FS 5,0 - 24	240	500	240	48.5	38.8	50.0	50.0	840
	TPA-FS 5,0 - 24	240	500	300	50.0	45.9	50.0	50.0	840
	TPA-FS 5,0 - 40	400	820	150	40.5	40.5	50.0	50.0	1480
	TPA-FS 5,0 - 40	400	820	180	48.6	48.2	50.0	50.0	1480
TPA-FS 5,0 - 40	400	820	200	50.0	50.0	50.0	50.0	1480	

*f_{ci} = cube concrete strength at time of lifting

HALFEN FRIMEDA LIFTING ANCHOR SYSTEM

TPA-FS Spread Anchor – no Special Requirements on the Reinforcement

Load capacities of HALFEN FRIMEDA Lifting anchors in beams and walls – no special reinforcement requirements

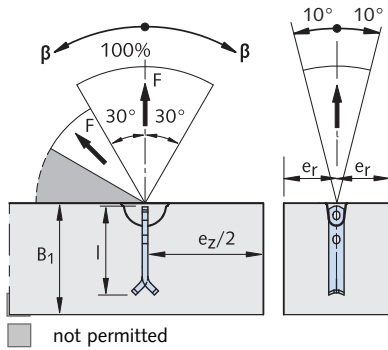

- > diagonal pull at $30^\circ < \beta \leq 60^\circ$ without reinforcement is only allowed for:
 - $\beta_W \geq 15 \text{ N/mm}^2 + 3 \text{ times minimum wall thickness}$
 - $\beta_W \geq 25 \text{ N/mm}^2 + 2.5 \text{ times minimum wall thickness}$
 - $\beta_W \geq 35 \text{ N/mm}^2 + 2 \text{ times minimum wall thickness}$
(minimum wall thickness = $2 \times e_r$)
- > F_{perm} can be assumed at 100% if concrete strength $\beta_W \geq 23 \text{ N/mm}^2$.
- > diagonal pull with cable/chain spread $\beta > 60^\circ$ is not permitted! See page 19.

Spread anchor in beams and walls – no special reinforcement requirements (load class 5,0-26,0)

Load class lifting link	Article number	Anchor length l [mm]	Minimum height of beams B1 [mm]	Wall thickness $2 \times e_r$ [mm]	Load capacity [kN] at concrete strength f_{ci}^* for				Axial spacing of anchors e_z [mm]
					Axial pull up to 30° [β]	Diagonal pull up to 45° [β]	Axial pull and Diagonal pull up to 60° [β]	Axial pull and Diagonal pull up to 60° [β]	
					15 N/mm ²	15 N/mm ²	25 N/mm ²	35 N/mm ²	
10,0	TPA-FS 7,5 - 26	260	550	300	61.1	48.9	75.0	75.0	900
	TPA-FS 7,5 - 26	260	550	400	75.0	60.7	75.0	75.0	900
	TPA-FS 7,5 - 26	260	550	500	75.0	71.8	75.0	75.0	900
	TPA-FS 7,5 - 30	300	630	250	60.3	48.2	75.0	75.0	1060
	TPA-FS 7,5 - 30	300	630	300	69.1	55.3	75.0	75.0	1060
	TPA-FS 7,5 - 30	300	630	400	75.0	68.6	75.0	75.0	1060
	TPA-FS 7,5 - 42	420	870	180	62.6	50.1	75.0	75.0	1540
	TPA-FS 7,5 - 42	420	870	240	75.0	62.1	75.0	75.0	1540
	TPA-FS 7,5 - 42	420	870	300	75.0	73.5	75.0	75.0	1540
	TPA-FS 10,0 - 30	300	630	400	84.7	67.8	100.0	100.0	1030
	TPA-FS 10,0 - 30	300	630	500	100.0	80.1	100.0	100.0	1030
	TPA-FS 10,0 - 30	300	630	600	100.0	91.9	100.0	100.0	1030
	TPA-FS 10,0 - 37	370	770	300	81.8	65.4	100.0	100.0	1310
	TPA-FS 10,0 - 37	370	770	400	100.0	81.2	100.0	100.0	1310
	TPA-FS 10,0 - 37	370	770	500	100.0	95.9	100.0	100.0	1310
	TPA-FS 10,0 - 52	520	1070	240	92.2	73.7	100.0	100.0	1910
	TPA-FS 10,0 - 52	520	1070	300	100.0	87.2	100.0	100.0	1910
	TPA-FS 10,0 - 52	520	1070	400	100.0	100.0	100.0	100.0	1910
26,0	TPA-FS 14,0 - 37	370	770	500	116.2	93.0	140.0	140.0	1230
	TPA-FS 14,0 - 37	370	770	600	133.3	106.6	140.0	140.0	1230
	TPA-FS 14,0 - 37	370	770	750	140.0	126.8	140.0	140.0	1230
	TPA-FS 14,0 - 46	460	950	400	119.0	95.2	140.0	140.0	1590
	TPA-FS 14,0 - 46	460	950	500	140.0	112.6	140.0	140.0	1590
	TPA-FS 14,0 - 46	460	950	600	140.0	129.1	140.0	140.0	1590
	TPA-FS 22,0 - 50	500	1030	600	170.7	136.6	220.0	220.0	1700
	TPA-FS 22,0 - 50	500	1030	800	211.8	169.5	220.0	220.0	1700
	TPA-FS 22,0 - 50	500	1030	1000	220.0	200.3	220.0	220.0	1700
	TPA-FS 22,0 - 62	620	1270	500	179.6	143.7	220.0	220.0	2180
	TPA-FS 22,0 - 62	620	1270	600	205.9	164.7	220.0	220.0	2180
	TPA-FS 22,0 - 62	620	1270	800	220.0	204.4	220.0	220.0	2180

* f_{ci} = cube concrete strength at time of lifting

HALFEN FRIMEDA LIFTING ANCHOR SYSTEM

TPA-FS Spread Anchor – with Reinforcement Subjected to Load

Load capacities of HALFEN FRIMEDA Lifting anchors in beams and walls; reinforcement subjected to load

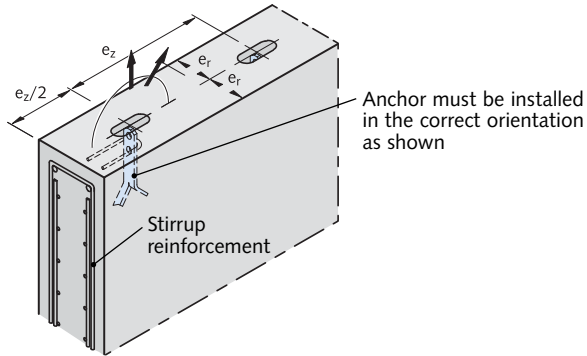

Required reinforcement:

1 – 4 → see table on page 26
"Reinforcement of thin precast concrete elements".

Cage stirrup reinforcement can be used in place of U-bars in beams.

Spread anchor in beams and walls – with reinforcement subjected to load (load class 2,5–5,0)

Load class lifting link	Article number	Anchor length l [mm]	Wall thickness $2 \times e_r$ [mm]	Load capacity [kN] at concrete strength f_{ci}^* for				Axial spacing of anchors e_z [mm]
				Axial pull up to 30° [β]	Diagonal pull up to 45° [β]	Axial pull and Diagonal pull up to 60° [β]	Axial pull and Diagonal pull up to 60° [β]	
				15 N/mm ²	15 N/mm ²	25 N/mm ²	35 N/mm ²	
2,5	TPA-FS 1,4 - 11	110	80	14.0	12.9	14.0	14.0	380
	TPA-FS 1,4 - 11	110	100	14.0	14.0	14.0	14.0	380
	TPA-FS 1,4 - 11	110	120	14.0	14.0	14.0	14.0	380
	TPA-FS 1,4 - 16	160	70	13.2	13.2	14.0	14.0	530
	TPA-FS 1,4 - 16	160	80	14.0	14.0	14.0	14.0	530
	TPA-FS 1,4 - 16	160	100	14.0	14.0	14.0	14.0	530
	TPA-FS 2,5 - 15	150	100	20.6	19.8	25.0	25.0	520
	TPA-FS 2,5 - 15	150	120	24.6	21.7	25.0	25.0	520
	TPA-FS 2,5 - 15	150	150	25.0	24.3	25.0	25.0	520
	TPA-FS 2,5 - 20	200	90	18.5	18.5	23.9	25.0	720
	TPA-FS 2,5 - 20	200	100	20.6	20.6	25.0	25.0	720
	TPA-FS 2,5 - 20	200	125	25.0	25.0	25.0	25.0	720
	TPA-FS 2,5 - 25	250	80	16.4	16.4	21.2	25.0	920
	TPA-FS 2,5 - 25	250	100	20.6	20.6	25.0	25.0	920
TPA-FS 2,5 - 25	250	120	24.7	24.7	25.0	25.0	920	
5,0	TPA-FS 5,0 - 18	180	240	45.1	36.1	50.0	50.0	600
	TPA-FS 5,0 - 18	180	300	50.0	40.4	50.0	50.0	600
	TPA-FS 5,0 - 18	180	400	50.0	46.6	50.0	50.0	600
	TPA-FS 5,0 - 24	240	180	48.7	43.5	50.0	50.0	840
	TPA-FS 5,0 - 24	240	200	50.0	45.8	50.0	50.0	840
	TPA-FS 5,0 - 24	240	240	50.0	50.0	50.0	50.0	840
	TPA-FS 5,0 - 40	400	160	43.2	43.2	50.0	50.0	1480
	TPA-FS 5,0 - 40	400	180	48.7	48.7	50.0	50.0	1480
TPA-FS 5,0 - 40	400	200	50.0	50.0	50.0	50.0	1480	

* f_{ci} = cube concrete strength at time of lifting

HALFEN FRIMEDA LIFTING ANCHOR SYSTEM

TPA-FS Spread Anchor – with Reinforcement Subjected to Load

Load capacities of HALFEN FRIMEDA Lifting anchors in beams and walls; reinforcement subjected to load

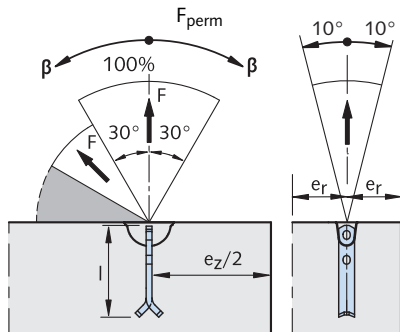

- diagonal pull at $30^\circ < \beta \leq 60^\circ$ without reinforcement is only allowed for:
 - $\beta_W \geq 15 \text{ N/mm}^2 + 3 \text{ times minimum wall thickness}$
 - $\beta_W \geq 25 \text{ N/mm}^2 + 2.5 \text{ times minimum wall thickness}$
 - $\beta_W \geq 35 \text{ N/mm}^2 + 2 \text{ times minimum wall thickness}$
(minimum wall thickness = $2 \times e_r$)
- F_{perm} can be assumed at 100% if concrete strength $\beta_W \geq 23 \text{ N/mm}^2$.
- diagonal pull with cable/chain spread $\beta > 60^\circ$ is not permitted! See page 19.

■ not permitted

Spread anchor in beams and walls – with reinforcement subjected to load (load class 5,0–26,0)

Load class lifting link	Article number	Anchor length l [mm]	Wall thickness $2 \times e_r$ [mm]	Load capacity [kN] at concrete strength f_{ci}^* for				Axial spacing of anchors e_z [mm]
				Axial pull up to 30° [β]	Diagonal pull up to 45° [β]	Axial pull and Diagonal pull up to 60° [β]	Axial pull and Diagonal pull up to 60° [β]	
				15 N/mm ²	15 N/mm ²	25 N/mm ²	35 N/mm ²	
10,0	TPA-FS 7,5 - 26	260	240	68.2	54.5	75.0	75.0	900
	TPA-FS 7,5 - 26	260	300	75.0	61.0	75.0	75.0	900
	TPA-FS 7,5 - 26	260	400	75.0	70.4	75.0	75.0	900
	TPA-FS 7,5 - 30	300	200	73.1	58.5	75.0	75.0	1060
	TPA-FS 7,5 - 30	300	240	75.0	64.0	75.0	75.0	1060
	TPA-FS 7,5 - 30	300	300	75.0	71.6	75.0	75.0	1060
	TPA-FS 7,5 - 42	420	160	60.0	60.0	75.0	75.0	1540
	TPA-FS 7,5 - 42	420	180	67.5	67.5	75.0	75.0	1540
	TPA-FS 7,5 - 42	420	200	75.0	75.0	75.0	75.0	1540
	TPA-FS 10,0 - 30	300	400	100.0	81.4	100.0	100.0	1030
	TPA-FS 10,0 - 30	300	500	100.0	91.0	100.0	100.0	1030
	TPA-FS 10,0 - 30	300	600	100.0	99.7	100.0	100.0	1030
	TPA-FS 10,0 - 37	370	300	100.0	89.3	100.0	100.0	1310
	TPA-FS 10,0 - 37	370	400	100.0	100.0	100.0	100.0	1310
	TPA-FS 10,0 - 37	370	500	100.0	100.0	100.0	100.0	1310
	TPA-FS 10,0 - 52	520	240	94.7	94.7	100.0	100.0	1910
	TPA-FS 10,0 - 52	520	300	100.0	100.0	100.0	100.0	1910
	TPA-FS 10,0 - 52	520	400	100.0	100.0	100.0	100.0	1910
26,0	TPA-FS 14,0 - 37	370	500	138.3	110.6	140.0	140.0	1230
	TPA-FS 14,0 - 37	370	600	140.0	121.2	140.0	140.0	1230
	TPA-FS 14,0 - 37	370	750	140.0	135.5	140.0	140.0	1230
	TPA-FS 14,0 - 46	460	350	140.0	118.9	140.0	140.0	1590
	TPA-FS 14,0 - 46	460	400	140.0	127.1	140.0	140.0	1590
	TPA-FS 14,0 - 46	460	500	140.0	140.0	140.0	140.0	1590
	TPA-FS 22,0 - 50	500	600	209.6	167.7	220.0	220.0	1700
	TPA-FS 22,0 - 50	500	800	220.0	193.6	220.0	220.0	1700
	TPA-FS 22,0 - 50	500	1000	220.0	216.5	220.0	220.0	1700
	TPA-FS 22,0 - 62	620	400	218.9	175.1	220.0	220.0	2180
	TPA-FS 22,0 - 62	620	600	220.0	214.5	220.0	220.0	2180
	TPA-FS 22,0 - 62	620	700	220.0	220.0	220.0	220.0	2180

* f_{ci} = cube concrete strength at time of lifting

HALFEN FRIMEDA LIFTING ANCHOR SYSTEM TPA-FS Spread Anchor

Load capacity, installation dimensions for tilt-up and turning

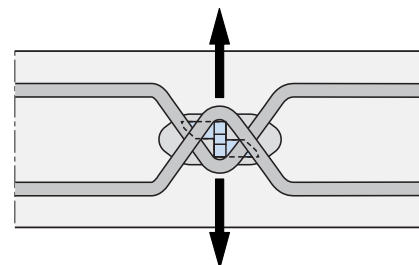
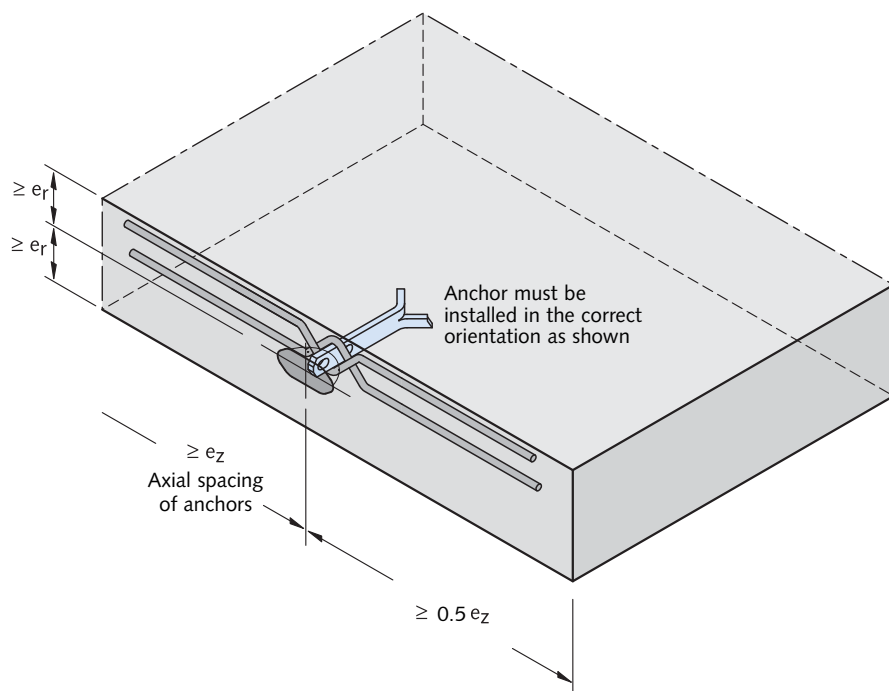

The horizontal legs of the tilt-up and turning reinforcement are located directly within the outermost position of the reinforced area.

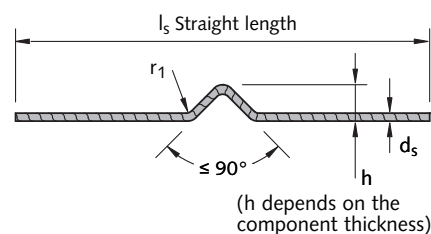

Material: Reinforcing steel B500B ①

Load capacities, installation dimensions for tilting and turning

Load class lifting link	Article number	$f_{ct} \geq 15 \text{ N/mm}^2$ perm. load capacities for tilting [kN]	Minimum edge distance e_r and axial spacing of anchors e_z for $\beta_W \geq 15 \text{ N/mm}^2$		Tilting and turning reinforcement		
			e_r [mm]	e_z [mm]	d_s [mm]	r_1 [mm]	l_s ① [mm]
2,5	TPA-FS 1,4 - 16	7.0	100	700	$\varnothing 10$	25	700
	TPA-FS 2,5 - 25	12.5	100	875	$\varnothing 12$	25	800
5,0	TPA-FS 5,0 - 40	25.0	150	1435	$\varnothing 16$	32	1000
10,0	TPA-FS 7,5 - 42	37.5	250	1470	$\varnothing 20$	40	1200
	TPA-FS 10,0 - 52	50.0	300	1820	$\varnothing 20$	40	1500
26,0	TPA-FS 14,0 - 46	70.0	525	1800	$\varnothing 25$	50	1800
	TPA-FS 22,0 - 62	110.0	710	2200	$\varnothing 28$	50	1800

① l_s = Length before bending reinforcement steel, bending radii according to DIN EN 1992

② 100% load is permitted with a concrete strength = $\beta_W \geq 23 \text{ N/mm}^2$

Required reinforcement: minimum standard reinforcement

HALFEN FRIMEDA LIFTING ANCHOR SYSTEM

TPA-FZ Two-hole Anchor

Anchor dimensions

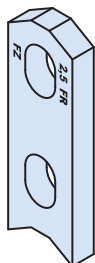

The head of the two-hole anchor is similar to the head of the spread anchor. The second hole in the lower part of the anchor allows an additional reinforcement bar to be used. Anchorage in the concrete is achieved with this additional reinforcement bar. Longer anchors with more additional holes can be made on request.

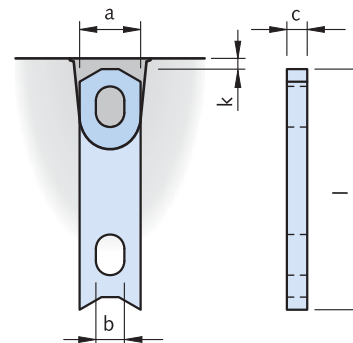

Dimensions TPA-FZ Two-hole anchors									
Load class lifting link	Article number Mill finish	Order no. 0070.020-	Article number Hot-dip galvanized	Order no. 0070.110-	a [mm]	b [mm]	c [mm]	l [mm]	k [mm]
2,5	TPA-FZ 1,4-9	00002	TPA-FZ 1,4- 9 FV	00064	30	14	6	90	10
	TPA-FZ 2,5-9	00004	TPA-FZ 2,5- 9 FV	00066	30	14	10	90	10
5,0	TPA-FZ 5,0-12	00007	TPA-FZ 5,0-12 FV	00069	40	18	15	120	10
10,0	TPA-FZ 7,5-16	00009	TPA-FZ 7,5-16 FV	00071	60	26	16	160	15
	TPA-FZ 10,0-17	00010	TPA-FZ 10,0-17 FV	00072	60	30	20	165	15
26,0	TPA-FZ 14,0-24	00011	TPA-FZ 14,0-24 FV	00073	80	35	20	240	15
	TPA-FZ 22,0-30	00013	TPA-FZ 22,0-30 FV	00074	90	35	28	300	15
	TPA-FZ 26,0-30	00012	TPA-FZ 26,0-30 FV	00075	120	65	30	300	15

Maximum edge and axial anchor spacings, load capacities

TPA-FZ	Edge and axial anchor spacings				Load capacities TPA-FZ		
	Article number	Anchor length l [mm]	Anchor spacings e _z [mm]	Minimum thickness of precast unit 2 × e _r [mm]	for f _{ci} ≥ 15 N/mm ² 100% F _{perm} Pull (β ≤ 30°) [kN]	for f _{ci} ≥ 15 N/mm ² 80% F _{perm} Diagonal pull (β > 30°) [kN]	for f _{ci} ≥ 25 N/mm ² Pull + Diagonal pull [kN]
2,5	TPA-FZ 1,4- 9	90	500	80	14	11,2	14
	TPA-FZ 2,0- 9	90	600	90	20	16	20
	TPA-FZ 2,5- 9	90	600	100	25	20	25
5,0	TPA-FZ 5,0-12	120	750	120	50	40	50
10,0	TPA-FZ 7,5-16	160	1200	130	75	60	75
	TPA-FZ 10,0-17	165	1200	140	100	80	100
26,0	TPA-FZ 14,0-24	240	1500	160	140	112	140
	TPA-FZ 22,0-30	300	1500	180	220	176	220
	TPA-FZ 26,0-30	300	1500	200	260	208	260

Observe the reinforcement specifications on page 34–35

HALFEN FRIMEDA LIFTING ANCHOR SYSTEM

TPA-FZ Two-hole Anchor

Reinforcement in anchor zone

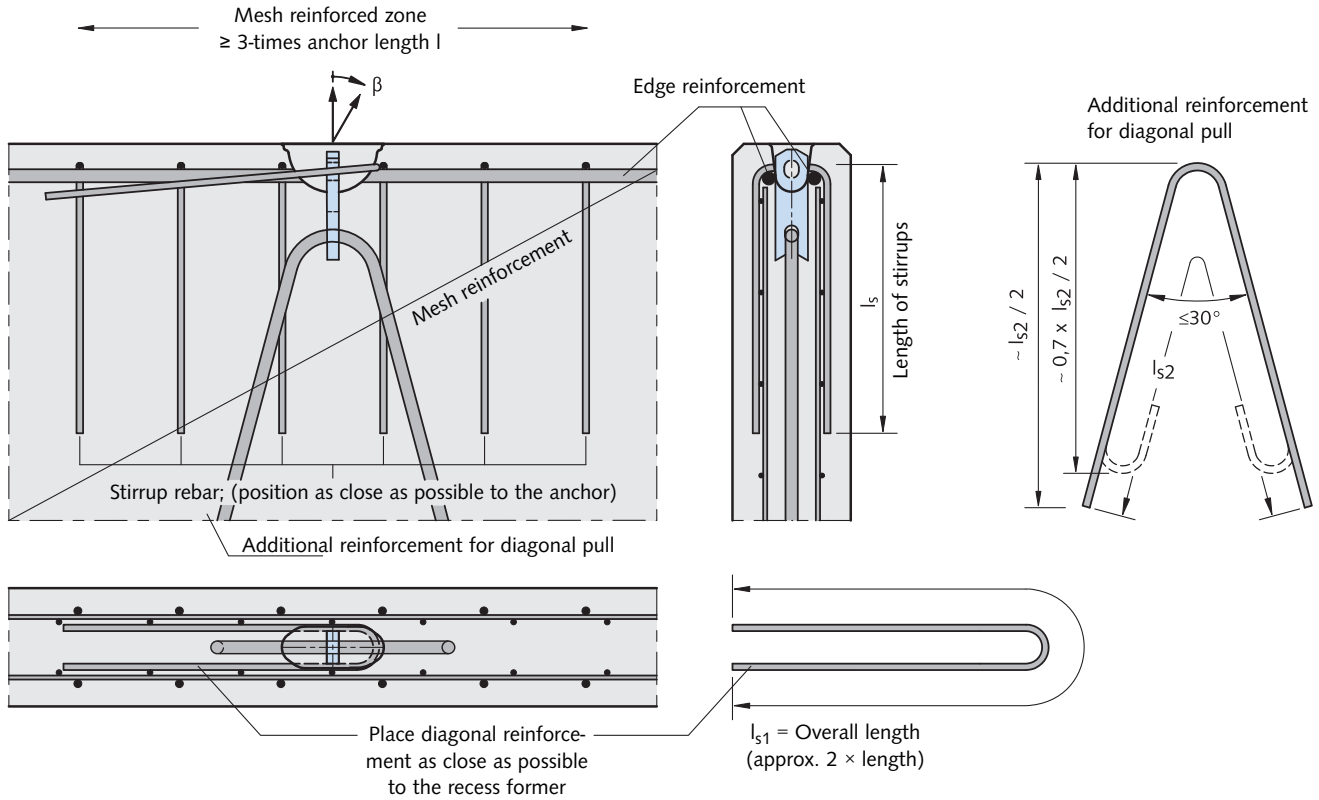

Reinforcement

Load class Anchor	Article number	Cross-wise mesh reinforcement [mm ² /m]	Reinforcement with Axial pull ($\beta \leq 30^\circ$)			Reinforcement with Diagonal pull ($\beta > 30^\circ - 45^\circ$)			
			Stirrup B500B $d_s \times l_s$ [mm]	Edge reinforcement B500B [mm]	② Additional reinforcement for pull B500B both sides $d_{s2} \times l_{s2}$ [mm]	Stirrup B500B $d_s \times l_s$ [mm]	Edge reinforcement B500B [mm]	② Additional reinforcement for pull B500B $d_{s2} \times l_{s2}$ [mm]	① Diagonal pull reinforcement B500B $d_{s1} \times l_{s1}$ [mm]
1,4	TPA-FZ 1,4- 9	131	2 $\phi 6 \times 400$	constructive	1 $\phi 10 \times 650$	4 $\phi 6 \times 400$	$\phi 8$	1 $\phi 10 \times 650$	$\phi 6 \times 900$
2,5	TPA-FZ 2,5- 9		2 $\phi 8 \times 600$		1 $\phi 12 \times 1000$	4 $\phi 8 \times 600$	$\phi 10$	1 $\phi 12 \times 1000$	$\phi 8 \times 1200$
5,0	TPA-FZ 5,0-12	131	2 $\phi 8 \times 800$	constructive	1 $\phi 16 \times 1500$	4 $\phi 10 \times 800$	$\phi 12$	1 $\phi 16 \times 1500$	$\phi 12 \times 1550$
7,5	TPA-FZ 7,5-16	188	2 $\phi 10 \times 800$	$\phi 10$	1 $\phi 20 \times 1750$	4 $\phi 10 \times 800$	$\phi 12$	1 $\phi 20 \times 1750$	$\phi 14 \times 2000$
10,0	TPA-FZ 10,0-17		4 $\phi 10 \times 800$		$\phi 12$	1 $\phi 25 \times 1850$	6 $\phi 10 \times 1000$	$\phi 14$	1 $\phi 25 \times 1850$
14,0	TPA-FZ 14,0-24	257	4 $\phi 10 \times 1000$	$\phi 14$	1 $\phi 28 \times 2350$	8 $\phi 10 \times 1000$	$\phi 14$	1 $\phi 28 \times 2350$	$\phi 20 \times 2600$
22,0	TPA-FZ 22,0-30		4 $\phi 12 \times 1200$		1 $\phi 28 \times 3000$	8 $\phi 10 \times 1200$	$\phi 16$	1 $\phi 28 \times 3000$	$\phi 25 \times 3000$
26,0	TPA-FZ 26,0-30		6 $\phi 12 \times 1200$		2 $\phi 28 \times 3050$	8 $\phi 12 \times 1200$	$\phi 16$	2 $\phi 28 \times 3050$	$\phi 28 \times 3450$

① No diagonal pull reinforcement is needed for concrete strength of:
 - $\beta_W \geq 15 \text{ N/mm}^2 + 3\text{-times minimum element thickness}$
 - $\beta_W \geq 25 \text{ N/mm}^2 + 2.5\text{-times minimum element thickness}$
 - $\beta_W \geq 35 \text{ N/mm}^2 + 2\text{-times minimum element thickness}$

② For other concrete strengths, the length L_{s2} of the additional reinforcement bar for pull may be reduced in relation to the permissible bond stress
 ($\beta_W = 25 \text{ N/mm}^2 : \times 0.8; \beta_W = 35 \text{ N/mm}^2 : \times 0.65$)

Please contact Leviat if the concrete strength is lower or if lightweight concrete is used.

HALFEN FRIMEDA LIFTING ANCHOR SYSTEM TPA-FZ Two-hole Anchor

Reinforcement in anchor zone – Diagonal pull reinforcement

With no diagonal pull reinforcement

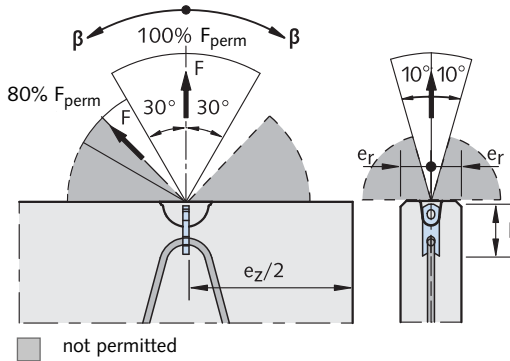

With diagonal pull reinforcement

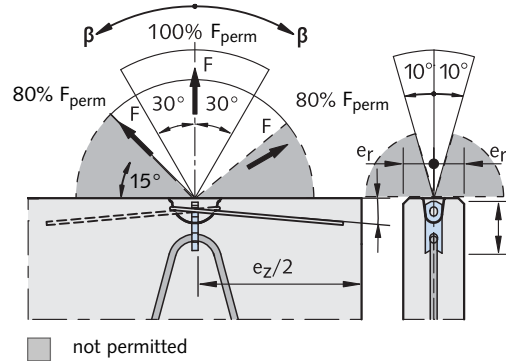

Diagonal pull at $30^\circ < \beta \leq 45^\circ$ with no diagonal pull reinforcement is allowable only if:

- $\beta_W \geq 15 \text{ N/mm}^2 + 3\text{-times min. element thickness}$
- $\beta_W \geq 25 \text{ N/mm}^2 + 2.5\text{-times min. element thickness}$
- $\beta_W \geq 35 \text{ N/mm}^2 + 2\text{-times min. element thickness}$
(minimum thickness of element: $e = 2 \times e_r$)



Diagonal pull is not permissible for two-hole anchors. Two-hole anchors are **not suitable for application in slab-type elements (floor slabs, stairs)**. The diagonal pull reinforcement has to be placed **close to the recess former** in direct contact with the anchor.



HALFEN FRIMEDA LIFTING ANCHOR SYSTEM

TPA-FA Double Shoulder Erection Anchor / TPA-FE Single Shoulder Erection Anchor (tilt-up)

Anchor dimensions TPA-FA

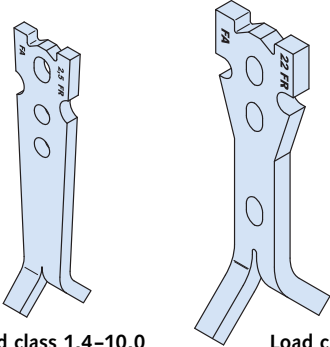

Load class 1,4-10,0

Load class 12,5-22,0

Due to the specially shaped anchor head the lifting clutch rests on the anchor and not the concrete when subjected to lateral loads; the pitching loads react through the anchor avoiding spalling in the concrete. Two semi-circular notches are provided in the anchor for additional pitching and turning reinforcement bars.

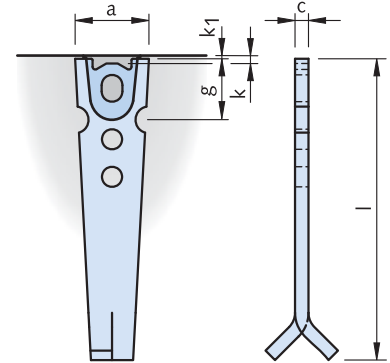

Dimensions – TPA-FA Double shoulder erection anchor (tilt-up)

Load class lifting link	Article number Mill finish	Order no. 0070.030-	Article number Hot-dip galvanized	Order no. 0070.110-	l [mm]	a [mm]	c [mm]	g [mm]	k [mm]	k ₁ [mm]
2,5	TPA-FA 1,4- 20	00001	TPA-FA 1,4- 20 FV	00001	200	55	6	45	10	5
	TPA-FA 2,5- 23	00002	TPA-FA 2,5- 23 FV	00002	230	55	10	45		
5,0	TPA-FA 5,0-29	00004	TPA-FA 5,0-29 FV	00004	290	70	15	70	10	5
10,0	TPA-FA 7,5-32	00005	TPA-FA 7,5-32 FV	00005	320	95	15	90	15	6
	TPA-FA 10,0-39	00006	TPA-FA 10,0-39 FV	00006	390	95	20	90		
26,0	TPA-FA 12,5-48	00007	TPA-FA 12,5-48 FV	00007	485	148	20	90	15	9
	TPA-FA 17,0-48	00008	TPA-FA 17,0-48 FV	00008	485	148	25	90		
	TPA-FA 22,0-50	00009	TPA-FA 22,0-50 FV	00009	500	148	30	90		

Anchor dimensions TPA-FE

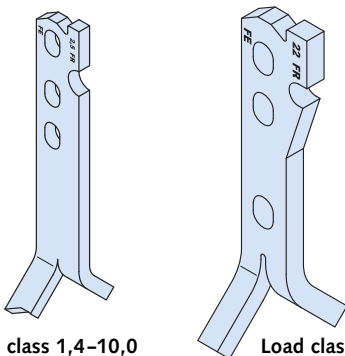

Load class 1,4-10,0

Load class 12,5-22,0

Compared to the TPA-FA tilt-up anchor the TPA-FE anchor can only be subjected to load in one direction. Its shape makes it particularly suitable for thin components. A single semi-circular notch is provided in the anchor for additional reinforcement bars for pitching and turning.

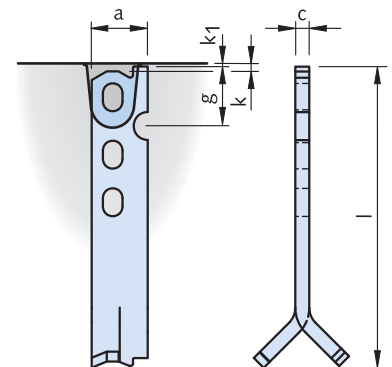

Dimensions – TPA-FE Single shoulder erection anchor (tilt-up)

Load class lifting link	Article number Mill finish	Order no. 0070.040-	Article number Hot-dip galvanized	Order no. 0070.110-	l [mm]	a [mm]	c [mm]	g [mm]	k [mm]	k ₁ [mm]
2,5	TPA-FE 1,4- 20	00001	TPA-FE 1,4- 20 FV	00010	200	40	6	42.2	10	5
	TPA-FE 2,5- 23	00002	TPA-FE 2,5- 23 FV	00011	230	40	10	42.5		
5,0	TPA-FE 5,0-29	00004	TPA-FE 5,0-29 FV	00013	290	55	15	50.5	10	5
10,0	TPA-FE 7,5-32	00005	TPA-FE 7,5-32 FV	00014	320	80	15	78.0	15	6
	TPA-FE 10,0-39	00006	TPA-FE 10,0-39 FV	00015	390	80	20	78.0		
26,0	TPA-FE 12,5-48	00007	TPA-FE 12,5-48 FV	00016	485	115	20	88.5	15	9
	TPA-FE 17,0-48	00008	TPA-FE 17,0-48 FV	00017	485	115	25	88.5		
	TPA-FE 22,0-50	00009	TPA-FE 22,0-50 FV	00018	500	115	30	88.5		

HALFEN FRIMEDA LIFTING ANCHOR SYSTEM

TPA-FA Double Shoulder Erection Anchor / TPA-FE Single Shoulder Erection Anchor (tilt-up)

Reinforcement in the anchor zone

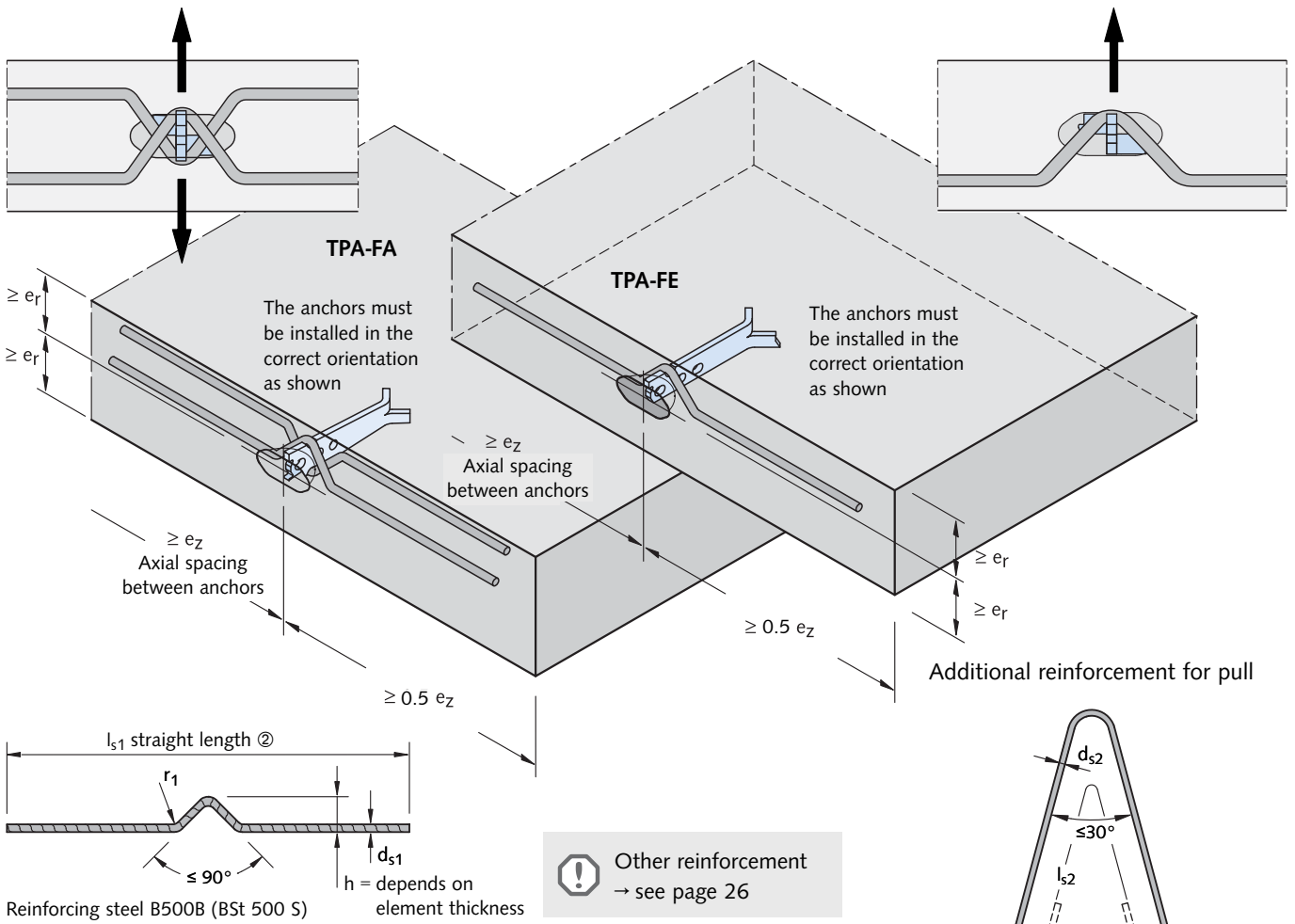

Additional reinforcement for tilt-up of thin-wall concrete precast elements ①

Load class lifting link	Load class anchor	Tilt-up and pitching reinforcement with $f_{ci} \geq 15 \text{ N/mm}^2$			Additional reinforcement for pull with $f_{ci} \geq 15 \text{ N/mm}^2$	
		d_{s1} ① [mm]	l_{s1} [mm]	r_1 [mm]	d_{s2} [mm]	l_{s2} [mm]
2,5	1,4	$\varnothing 10$	700	25	$\varnothing 10$	650
	2,5	$\varnothing 12$	800		$\varnothing 12$	1000
5,0	5,0	$\varnothing 16$	1000	32	$\varnothing 16$	1500
10,0	7,5	$\varnothing 20$	1200	40	$\varnothing 20$	1750
	10,0	$\varnothing 20$	1500		$\varnothing 20$	1900
26,0	12,5	$\varnothing 25$	1500	50	$\varnothing 25$	2200
	17,0	$\varnothing 25$	1800		$\varnothing 28$	2500
	22,0	$\varnothing 28$	1800		$\varnothing 28$	3000

① Reinforcement from page 26 No. 1 + 2 is required
 ② l_{s1} = length before bending / bending radii according to DIN EN 1992
 For other concrete strengths the length l_{s1} of the tilt-up reinforcement can be reduced in relation to the permitted composite stresses.
 ($\beta_W = 25 \text{ N/mm}^2 : \times 0.8; \beta_W = 35 \text{ N/mm}^2 : \times 0.65$)

The horizontal legs of the pitching and turning reinforcement are located directly towards the inside of the outermost reinforcement. The bilateral pitching reinforcement also acts as diagonal pull reinforcement. No further diagonal reinforcement is required.

Without additional reinforcement for pull:

Mesh, stirrups and edge reinforcement as for TPA-FS.

With additional reinforcement for pull:

Mesh, stirrups and edge reinforcement as for TPA-FZ.

HALFEN FRIMEDA LIFTING ANCHOR SYSTEM

TPA-FA Double Shoulder Erection Anchor / TPA-FE Single Shoulder Erection Anchor (tilt-up)

Load capacities, installation dimensions

Lifting TPA-FA

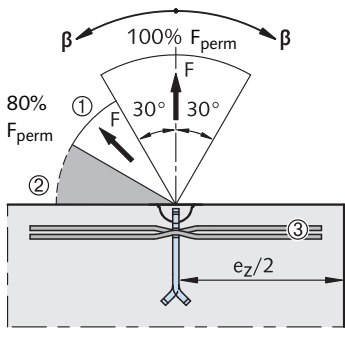

TPA-FA, tilt-up

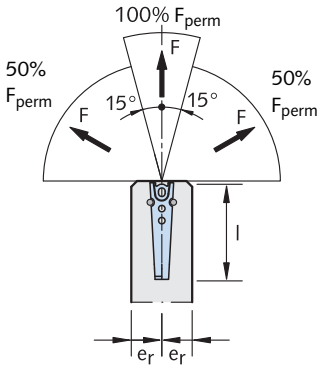

- ① F_{perm} can be assumed at 100% if concrete strength $\beta_w \geq 23 \text{ N/mm}^2$
- ② Angles of $\beta > 60^\circ$ due to cable spread are not allowed! → See page 19.
- ③ Insert the tilt-up reinforcement in the anchor notches.

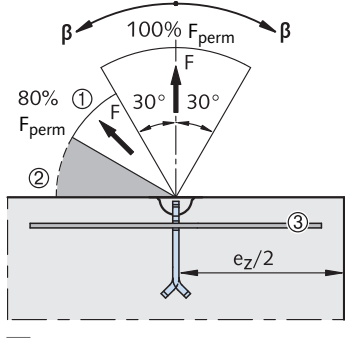

Lifting TPA-FE

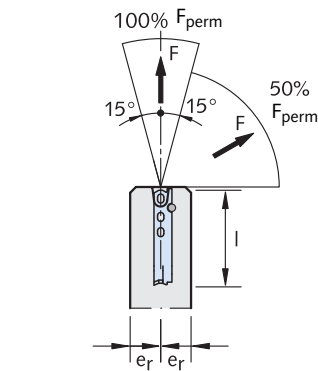

TPA-FE, tilt-up



Load capacities, installation dimensions

Load class lifting link	Load class anchor	Anchor length l [mm]	Axial e_z [mm]	Minimum thickness ($2 \times e_r$)				Lifting  Pull ($\beta \leq 30^\circ$) 15 N/mm ² [kN]	Lifting  Diagonal pull ($\beta > 30^\circ$) 15 N/mm ² 25 N/mm ² [kN]		Tilt-up  15 N/mm ² 25 N/mm ² [kN]	
				with additional reinforcement for pull		without additional reinforcement for pull			Pull/ Diag. pull [kN]	15 N/mm ² 25 N/mm ² [kN]	15 N/mm ² 25 N/mm ² [kN]	
				TPA-FE [mm]	TPA-FA [mm]	TPA-FE [mm]	TPA-FA [mm]					
2,5	1,4	200	700	90	100	90	100	14	11	14	7	7
	2,5	230	800	100	120	110	120	25	22	25	12	13
5,0	5,0	290	1000	140	160	170	180	47	37	50	25	25
10,0	7,5	320	1200	160	175	200	220	65	52	75	37	38
	10,0	390	1500	200	240	250	280	85	65	100	50	50
26,0	12,5	485	1500	220	240	320	350	120	96	125	62	63
	17,0	485		280	300	380	400	140	112	170	85	85
	22,0	500		360	380	470	500	200	160	220	110	110

Note: Observe the notes on reinforcement on pages 26

HALFEN FRIMEDA LIFTING ANCHOR SYSTEM

TPA-FU Universal Anchor

Anchor dimensions, load capacities, installation dimensions, reinforcement

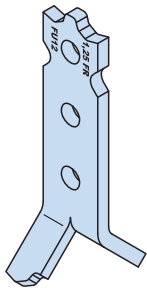

This anchor combines the advantages of spread-, two-hole- and tilt-up anchor but requires only a very small recess in the precast element.

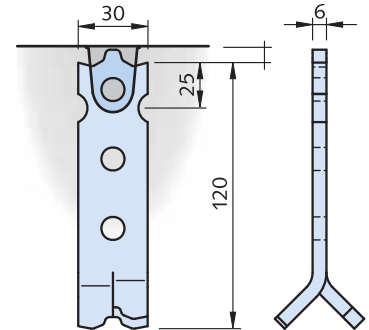

The tilt-up and transport anchors used in very thin precast concrete elements (e.g. balcony parapet panels) must fulfil the special requirements for this application. The HALFEN FRIMEDA TPA-FU Universal anchor 1,25-12 has been specially designed for this specific application, and is therefore ideal for tilt-up, turning and lifting this type of element.

Recommended reinforcement

Additional reinforcement is required for distributing loads in very thin panels or panels with only a single-layer of reinforcement. Dedicated turning and tilting reinforcement must be used in this application (→ see illustration on the left).

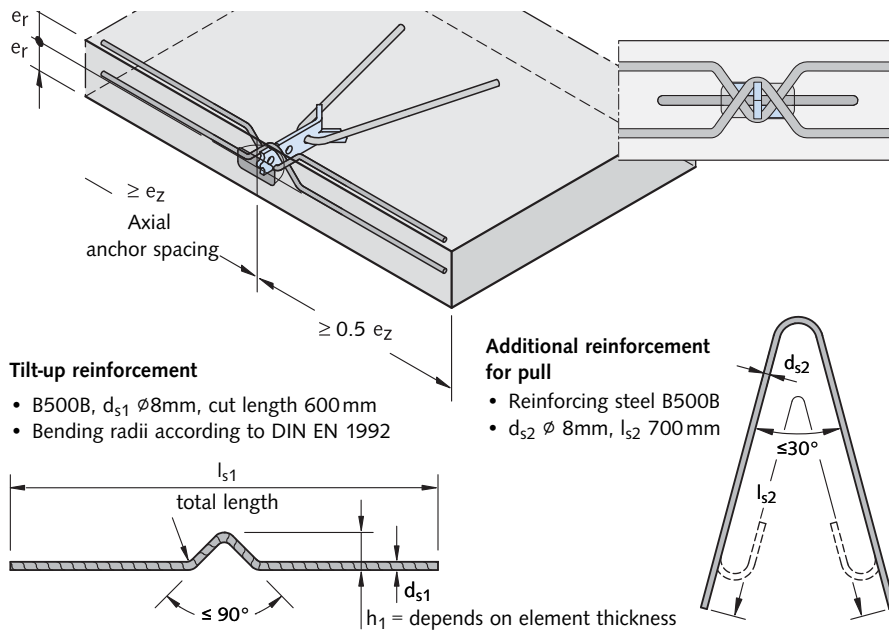

Further reinforcement:
→ see page 26 (load class 1,4)

Allowable loads TPA-FU Universal anchor

Article number	Minimum element thickness [mm]	Axial pull up to 30°			Diagonal pull up to 45°			Tilt-up and turning			Minimum axial spacing e_z [mm]
		Permitted load at concrete strength f_{ci} = 15 N/mm ²	Permitted load at concrete strength f_{ci} = 25 N/mm ²	Permitted load at concrete strength f_{ci} = 35 N/mm ²	Permitted load at concrete strength f_{ci} = 15 N/mm ²	Permitted load at concrete strength f_{ci} = 25 N/mm ²	Permitted load at concrete strength f_{ci} = 35 N/mm ²	Permitted load at concrete strength f_{ci} = 15 N/mm ²	Permitted load at concrete strength f_{ci} = 25 N/mm ²	Permitted load at concrete strength f_{ci} = 35 N/mm ²	
TPA-FU 1,25-12	60	10.0 ^①	12.5 ^①	12.5 ^①	10.0 ^①	12.5 ^①	12.5 ^①	-	-	-	240
	80	12.5 ^①	12.5 ^①	12.5 ^①	10.0 ^①	12.5 ^①	12.5 ^①	4.1	4.6	5.0	
	100	12.5 ^①	12.5	12.5	10.0 ^①	12.5	12.5	4.5	5.2	5.6	
	120	12.5	12.5	12.5	12.5	12.5	12.5	4.8	5.6	6.0	
	140	12.5	12.5	12.5	12.5	12.5	12.5	6.0	6.25	6.25	
	160	12.5	12.5	12.5	12.5	12.5	12.5	6.25	6.25	6.25	

① with additional reinforcement for pull \varnothing 8 × 700

HALFEN FRIMEDA LIFTING ANCHOR SYSTEM

TPA-FF Flat Foot Anchor

Anchor dimensions TPA-FF

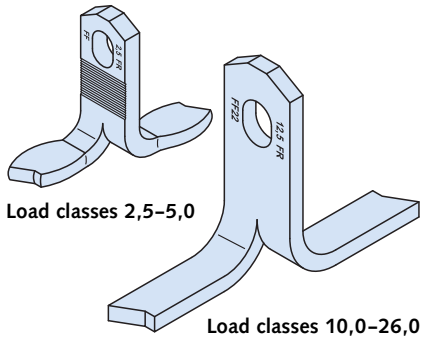

For all large surface, thin precast elements that are lifted perpendicular to their main face.

This anchor is an alternative to the TPA-FP Plate anchor. The main use is in elements with a concrete strength at lifting of 25 N/mm² and more.

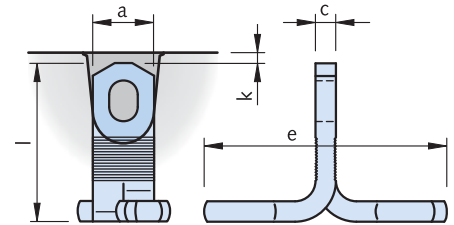

Load capacity of the flat foot anchor

To ensure load distribution in the flat foot anchor, it is crucial that the flat foot is positioned under the main reinforcement. If this is not possible, suitable additional reinforcement must be placed over the flat foot.

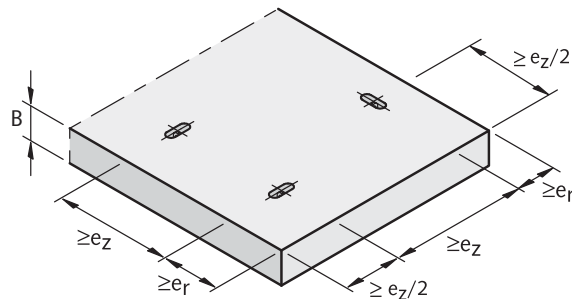

Additional reinforcement is not included in delivery.



Required element dimensions → see table on page 41

Dimensions – TPA-FF Flat foot anchor

Load class lifting link	Article number Mill finish	Order no. 0070.070-	Article number Hot-dip galvanized	Order no. 0070.110-	a [mm]	c [mm]	l [mm]	e [mm]	k [mm]
2,5	TPA-FF 1,4-6	00002	TPA-FF 1,4-6 FV	00020	30	6	65	70	10
	TPA-FF 2,5-7	00004	TPA-FF 2,5-7 FV	00022	30	10	75	94	
5,0	TPA-FF 5,0-12	00007	TPA-FF 5,0-12 FV	00025	40	15	125	105	10
10,0	TPA-FF 7,5-17	00009	TPA-FF 7,5-17 FV	00027	60	16	170	120	15
	TPA-FF 10,0-20	00010	TPA-FF 10,0-20 FV	00028	60	20	200	120	
26,0	TPA-FF 12,5-22	00011	TPA-FF 12,5-22 FV	00029	80	16	220	200	15
	TPA-FF 17,0-27	00012	TPA-FF 17,0-27 FV	00030	80	20	270	200	
	TPA-FF 22,0-31	00013	-	-	90	28	310	200	

HALFEN FRIMEDA LIFTING ANCHOR SYSTEM TPA-FF Flat Foot Anchor

Additional reinforcement in the anchor zone

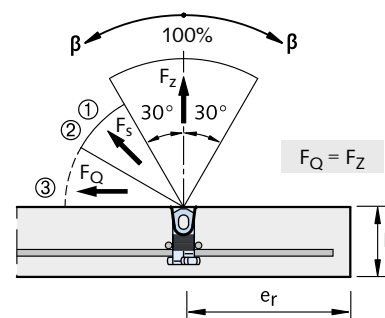
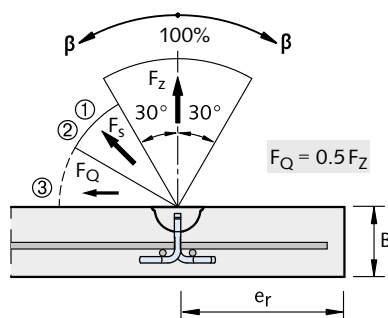
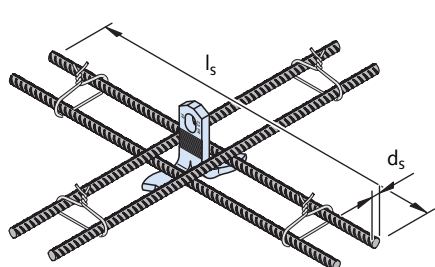

Where loads are acting towards the edge of the element, insert diagonal pull reinforcement as for spread or two-hole anchors.
(→ see page 26).

Additional reinforcement has to be placed as close as possible to the anchor.

- ① Diagonal pull at $30^\circ < \beta \leq 60^\circ$ without diagonal pull reinforcement only permissible when:
 - $\beta_W \geq 15 \text{ N/mm}^2 + 3\text{-times min. element thickness}$
 - $\beta_W \geq 25 \text{ N/mm}^2 + 2.5\text{-times min. element thickness}$
 - $\beta_W \geq 35 \text{ N/mm}^2 + 2\text{-times min. element thickness}$
- ② If concrete strength $\beta_W \geq 23 \text{ N/mm}^2$ then $F_Q = F_s = F_z$
- ③ **Cable spread of $\beta > 60^\circ$ is not permitted!** → See page 19.

Required reinforcement: top and bottom reinforcement, crosswise → see page 34
The element must be dimensioned for load case 'transport'.

Element dimensions, additional reinforcement and load capacities

Load class lifting link	Article number	Anchor length l [mm]	Minimum element thickness B [mm]	Min. edge distance or axial anchor spacing		Additional reinforcement B500B		Load capacity Axial pull, Diagonal pull, Transverse pull at concrete strength f_{ci}		
				e_r [mm]	e_z [mm]	d_s [mm]	l_s [mm]	$\geq 15 \text{ N/mm}^2$ [kN]	$\geq 25 \text{ N/mm}^2$ [kN]	$\geq 35 \text{ N/mm}^2$ [kN]
2,5	TPA-FF 1,4 - 6	65	95 ^④	140	210	8	250	14.0	14.0	14.0
	TPA-FF 2,5 - 7	75	105 ^④	160	240		300	20.0	25.0	25.0
5,0	TPA-FF 5,0 - 12	125	160	260	390	12	500	44.0	50.0	50.0
10,0	TPA-FF 7,5 - 17	170	215	340	510	14	600	54.6	70.4	75.0
	TPA-FF 10,0 - 20	200	245	400	600	14	600	77.4	100.0	100.0
26,0	TPA-FF 12,5 - 22	220	265	440	660	16	750	96.8	125.0	125.0
	TPA-FF 17,0 - 27	270	315	540	810	16	900	131.6	170.0	170.0
	TPA-FF 22,0 - 31	310	355	620	930	20	1100	170.4	220.0	220.0

④ The elements thickness can be reduced, if corrosion protection is ensured.

HALFEN FRIMEDA LIFTING ANCHOR SYSTEM

TPA-FP Plate Anchor

Dimensions TPA-FP

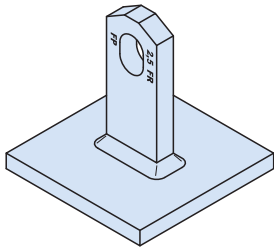

The plate anchor is suitable for all large surface, thin precast elements. Additional cross-wise reinforcement on the anchor plate must be used.

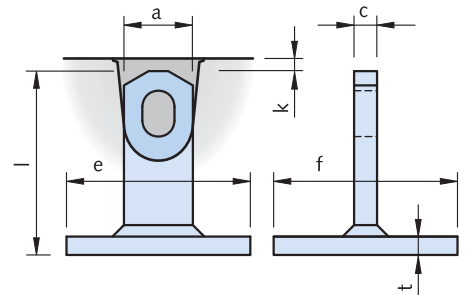

Dimensions TPA-FP Plate anchor

Article number Mill finish	Order no. 0070.050-	Article number Hot-dip galvanized	Order no. 0070.110-	Load class	a [mm]	c [mm]	l [mm]	e x f [mm]	t [mm]	k [mm]
TPA-FP 1,4- 5	00001	TPA-FP 1,4- 5 FV	00076	2,5	30	6	55	80 x 80	8	10
TPA-FP 2,5- 8	00002	TPA-FP 2,5- 8 FV	00077			10	80			
TPA-FP 5,0-12	00003	TPA-FP 5,0-12 FV	00078	5,0	40	15	120	100 x 100	10	10
TPA-FP 10,0-16	00004	TPA-FP 10,0-16 FV	00079	10,0	60	20	160	140 x 140	12	15

Other load classes and anchor lengths are available on request

Load capacities, installation dimensions and additional reinforcement

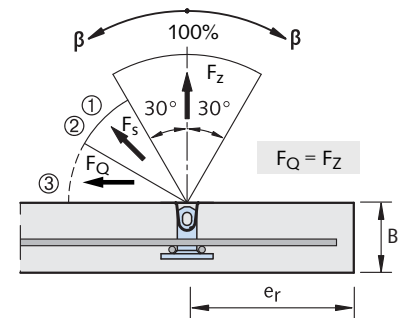
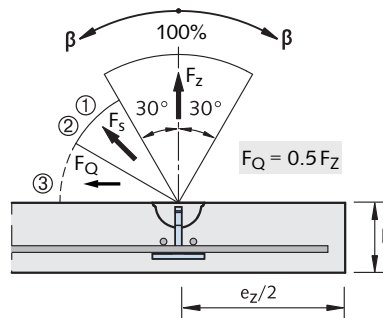
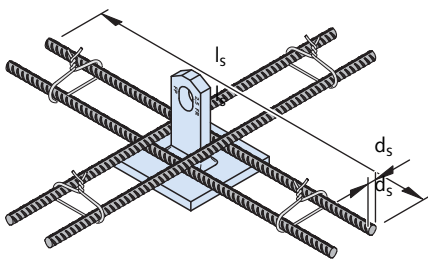

It is important that the reinforcement bars are in direct contact with the anchor base plate!

The element must be dimensioned for load case 'transport'.

- ① Diagonal pull at $30^\circ < \beta \leq 60^\circ$ without diagonal pull reinforcement only permissible when:
 - $\beta_W \geq 15 \text{ N/mm}^2 + 3\text{-times min. element thickness}$
 - $\beta_W \geq 25 \text{ N/mm}^2 + 2.5\text{-times min. element thickness}$
 - $\beta_W \geq 35 \text{ N/mm}^2 + 2\text{-times min. element thickness}$

- ② If concrete strength $\beta_W \geq 23 \text{ N/mm}^2$ then $F_Q = F_S = F_Z$

- ③ Cable spread of $\beta > 60^\circ$ is not permitted! → See page 19.

Required reinforcement: top and bottom reinforcement, crosswise → see table

Element dimensions, additional reinforcement and load capacities

Load class lifting link	Article number	Anchor length l [mm]	Minimum element thickness B [mm]	Min. edge distance or axial anchor spacing		Top and bottom crosswise reinforcement [mm ² /m]	Additional reinforcement		Load capacity		
				e _r [mm]	e _z [mm]		d _s [mm]	l _s [mm]	Pull (β ≤ 30°) f _{ci} = 15 N/mm ² [kN]	Diagonal pull (β > 30°) f _{ci} = 15 N/mm ² [kN]	Pull / Diagonal pull f _{ci} = 25 N/mm ² [kN]
2,5	TPA-FP 1,4 - 5	55	85	115	230	2 x 131	8	200	14.0	11.2	14.0
	TPA-FP 2,5 - 8	80	110	165	330	2 x 131	10	300	25.0	20.0	25.0
5,0	TPA-FP 5,0 - 12	120	150	240	480	2 x 131	12	450	50.0	40.0	50.0
10,0	TPA-FP 10,0 - 16	160	195	330	660	2 x 181	16	600	100.0	80.0	100.0

HALFEN FRIMEDA LIFTING ANCHOR SYSTEM

TPA-FX Sandwich Panel Anchor

Dimensions TPA-FX

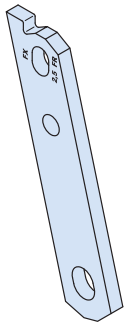

This anchor is specially designed for use with precast sandwich panels. It provides a suspension point close to the gravity axis allowing the element to be transported and erected in an upright position.

We recommend using hot-dip galvanized anchors to ensure sufficient corrosion protection.

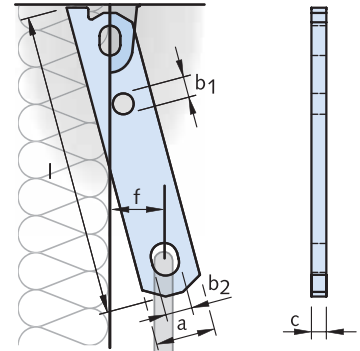

Dimensions TPA-FX Sandwich panel anchor

Load class lifting link	Article number Mill finish	Order no. 0070.090-	Article number Hot-dip galvanized	Order no. 0070.090-	a [mm]	b ₁ [mm]	b ₂ [mm]	c [mm]	l [mm]	f [mm]
2,5	TPA-FX 2,5-25	00001	TPA-FX 2,5-25 FV	00006	40	14	18	10	250	48
5,0	TPA-FX 5,0-30	00002	TPA-FX 5,0-30 FV	00007	60	17.5	26	16	300	53
10,0	TPA-FX 7,5-35	00003	TPA-FX 7,5-35 FV	00008	80	25	35	16	350	55
	TPA-FX 10,0-35	00004	TPA-FX 10,0-35 FV	00009				20		
26,0	TPA-FX 17,0-40	00005	TPA-FX 17,0-40 FV	00010	100	30	35	20	400	66

Face-down production (Standard)

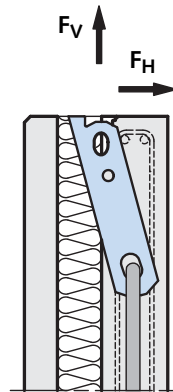
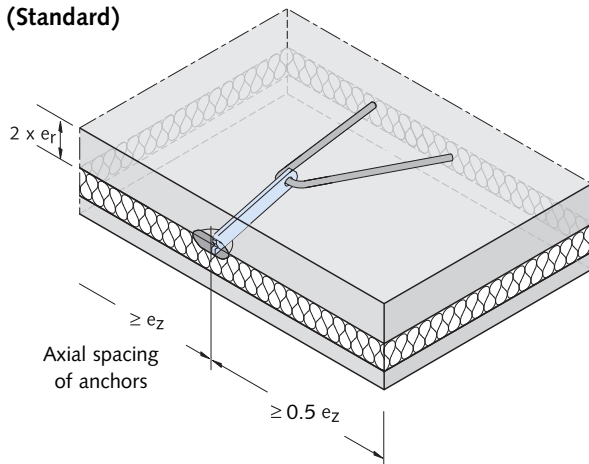

The specially designed slanted head of the TPA-FX Sandwich panel anchor can be inserted close to the gravity axis in large, precast concrete sandwich panels.

The panel hangs nearly upright during transport and installation.

The head shape is compatible with the HALFEN TPA Accessories range.

Face-up production

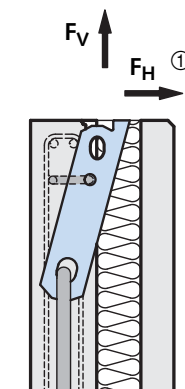
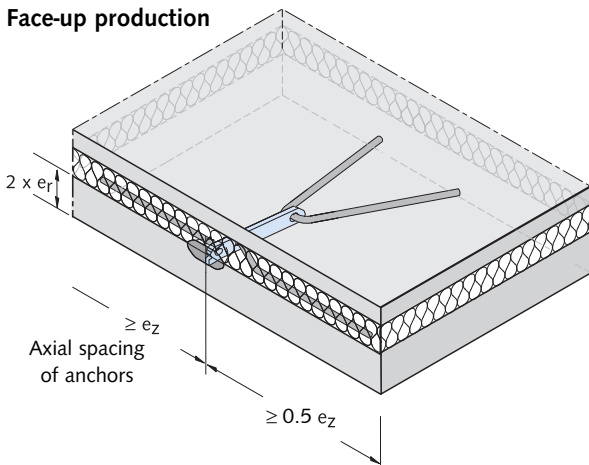

① tilt-up reinforcement required, if F_H is in the direction of the facing layer, i.e. with face-up produced elements

HALFEN FRIMEDA LIFTING ANCHOR SYSTEM

TPA-FX Sandwich Panel Anchor

Additional reinforcement TPA-FX

Tilt-up reinforcement ①

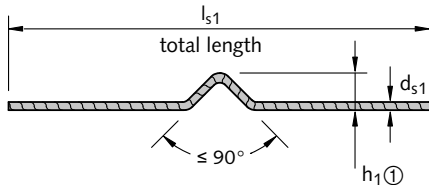

- Reinforcing steel B500B
- Bending radii acc. to DIN EN 1992

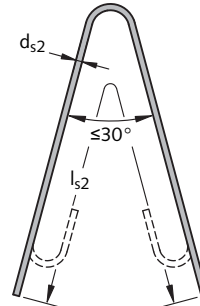

② h_1 = thickness of the element, but at least as in the table

Additional reinforcement for pull

Element dimensions, additional reinforcement and load capacities

Load class lifting link	Article number	Minimum distances		Stirrup for pull B500B (see page 24)	Reinforcement			Additional reinforcement for pull [®] (not included in delivery)		Load capacities perm. load capacities at concrete strength $f_{ci} \ge 15 \text{ N/mm}^2$	
		Element thickness load bearing inner slab $2 \times e_r$ [mm]	Minimum axial anchor spacing e_z [mm]		$\varnothing \times \text{length}$ [mm]	Tilt-up reinforcement [®] (not included in delivery)	Additional reinforcement for pull [®] (not included in delivery)	Load capacities			
								Axial pull [kN]	Transverse pull [kN]		
2,5	TPA-FX 2,5-25	100	600	$2 \varnothing 8 \times 600$	d_{s1}	l_{s1}	h_1 ②	d_{s2}	l_{s2}	25.0	8.0
5,0	TPA-FX 5,0-30	120	750	$2 \varnothing 8 \times 800$	10	600	≥ 60	14	800	50.0	18.0
10,0	TPA-FX 7,5-35	130	1200	$2 \varnothing 10 \times 800$	14	700	≥ 80	16	1200	75.0	26.0
	TPA-FX 10,0-35	140	1200	$4 \varnothing 10 \times 800$	16	800	≥ 100	25	1400	100.0	35.0
26,0	TPA-FX 17,0-40	180	1500	$4 \varnothing 12 \times 1200$	20	900	≥ 120	25	1800	170.0	50.0

③ To ensure adequate corrosion protection, we recommend hot-dip galvanized additional reinforcement.

④ The loads in diagonal pull must be reduced to 80% – irrespective of concrete strengths. In general, diagonal pull should be avoided.

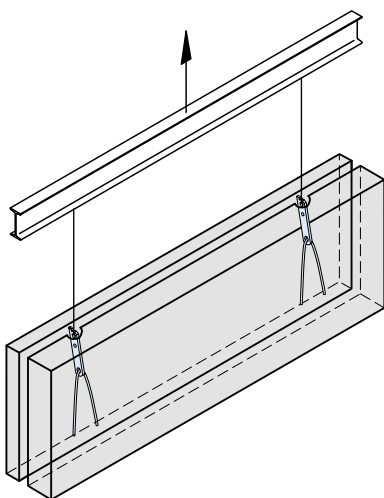

When using TPA-FX Anchors for tilt-up and transport we recommend using a spreader beam. This helps to prevent spalling of the concrete when tilting, transporting or installing.

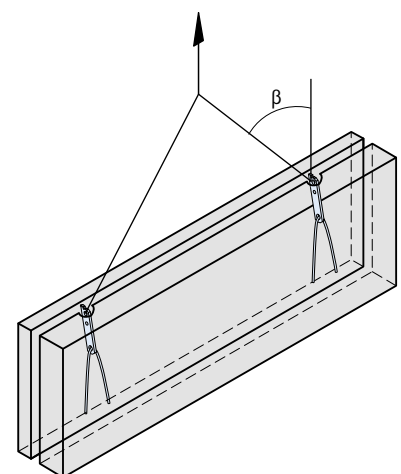

Not advisable (diagonal pull, $\beta > 30^\circ$ is not advisable)



Diagonal pull only permitted with concrete strength $f_{ci} \ge 25 \text{ N/mm}^2$ and $\beta \le 30^\circ$.

HALFEN FRIMEDA LIFTING ANCHOR SYSTEM

TPA-FD Double-Head (Column) Anchor

TPA-FD Double-head (column) anchor

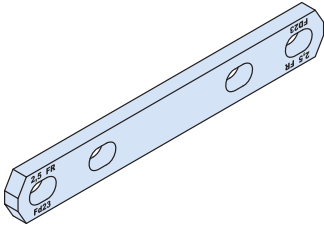

This anchor is similar to the head of the two-hole anchor. The TPA-FD Anchor was specially developed for lifting rectangular columns. For round profiled columns or for small edge distances we recommend installing the TPA-FA tilt-up anchor.

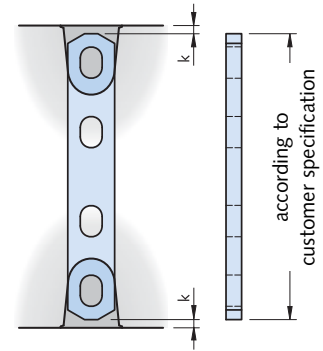

Allowable loads: TPA-FD Double-head (column) anchor

Load class lifting link	Article number	Allowable column weight for $f_{ct} \geq$		Element thickness ^② / minimum distances				Reinforcement	
		15 N/mm ²	25 N/mm ²	a_s ^②	b_s ^②	e_s	k	d_s	l_s
		[kN]	[kN]	[mm]	[mm]	[mm]	[mm]	[mm]	[mm]
2,5	TPA-FD 2,5-L ^①	40.0	50.0	150	180	300	10	12	750
5,0	TPA-FD 5,0-L	80.0	100.0	190	300	400	10	16	1000
10,0	TPA-FD 7,5-L	120.0	150.0	250	400	500	15	20	1200
	TPA-FD 10,0-L	160.0	200.0	300	500	500	15	25	1500
26,0	TPA-FD 12,5-L	200.0	250.0	400	600	800	15	25	1500
	TPA-FD 17,0-L	272.0	340.0	400	700	800	15	28	1600
	TPA-FD 22,0-L	352.0	440.0	475	800	800	15	28	2000

① The length of the TPA-FD is according to the customer's specification. Anchor length $l =$ column dimension a_s minus $2 \times$ anchor head cover k . Article number: 0070-089-00001

② Dimension a_s is a minimum dimension; this dimension **must not** fall below this value. The dimension b_s can be further reduced if there is a reduction in the load capacity or if lifting adhesion is higher. (Contact us for more detailed information. For contact information → see back cover).

Lifting / Tilt-up columns

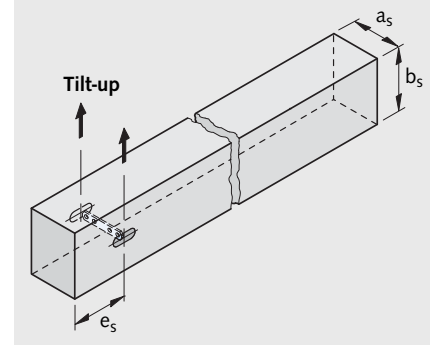
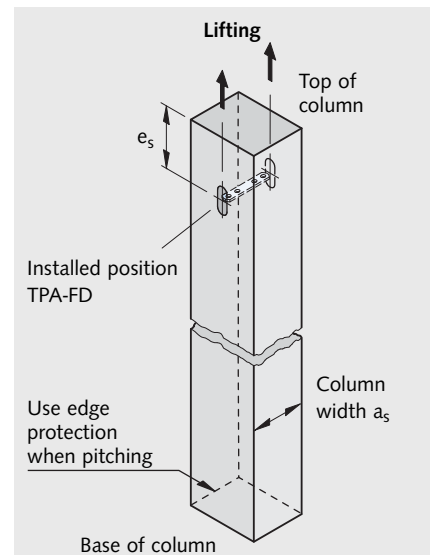

Required additional reinforcement

Recess former are used at both ends of the anchor. The anchor and recess former assembly is then passed between the reinforcement bars and fastened to the formwork at both ends. The additional reinforcement bars are then pushed through the holes of the anchor and wired in place.

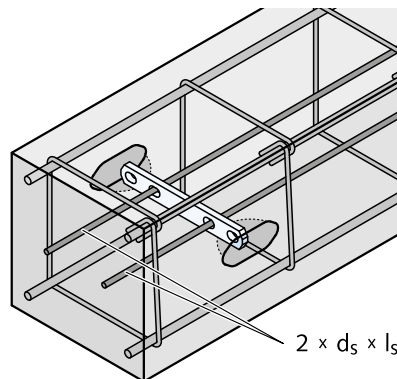

Additional reinforcement as for the two-hole anchor.

⚠ The larger the dimension e_s the greater the load on the anchor when tilting, but the lower the load on the edge at the base of the column.

HALFEN FRIMEDA LIFTING ANCHOR SYSTEM

HALFEN FRIMEDA Recess Former – Installation and Application

Recess former

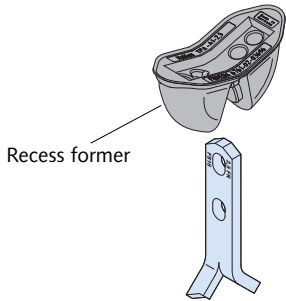

The plastic recess formers are used for easy attachment to the formwork.

Installation

- › the open recess former is placed over the anchor head
- › close the recess former to secure the anchor
- › the recess former and the anchor are then fixed to the formwork

Holding plates

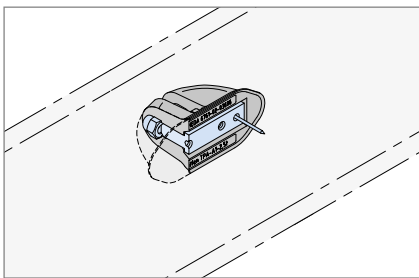

The TPA-H1 Holding plate consists of a baseplate with two bolts. Two or four nail holes are provided in the baseplate.

The plate can either be nailed or welded. The recess former is easily fitted onto the bolts for installation.

The holding plate has no screw-thread.

This allows the formwork to be simply pulled off without first having to remove the plate.

TPA-A4 Recess former

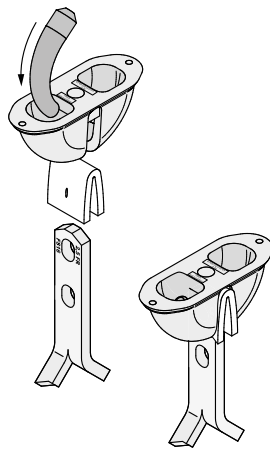

The anchor head is pressed into the TPA-A Z01 Foam strips and secured in the recess former using the TPA-A E01 Wedge as shown above. The wedge is easily removed to release the recess former. The recess former can then be removed in a vertical direction.

Installation

- › the lifting anchors are fixed to the formwork with recess formers of the same load group
- › apply formwork oil to the exposed surfaces of the recess formers
- › insert or place additional reinforcement
- › required transverse load reinforcement is always applied opposite to the load force direction

TPA-S1 Holding bolts

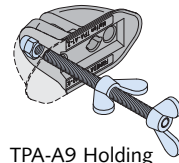

TPA-A1 TPA-A9 Holding bolt with thread

The **TPA-S1 Holding bolt with thread** is used for fixing the recess former. The bolt has a fixed wing-nut at one end. A second, identical, freely adjustable wing-nut is screwed onto the thread.

TPA-S2 Holding bolt

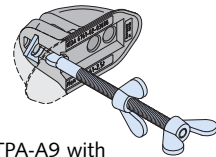

TPA-A1 TPA-A9 with bayonet holding bolt

The **TPA-S2 Bayonet holding bolt** consists of a threaded holding bolt with a bayonet fitting.

Installation

- › the bayonet holding bolt is inserted into the bayonet connection of the recessed unit, and then turned 90°
- › the upper wingnut is turned to be at right-angles to the lengthwise direction of the recessed unit
- › the recess former is then secured against the formwork with the second wing nut

HALFEN FRIMEDA LIFTING ANCHOR SYSTEM

Holding Plates and Holding Bolts – Installation and Application

Notes on anchor installation

Only careful installation of the anchors guarantees their correct function and optimal safety in lifting. Always use the available installation accessories for all applications.

The A1 recess former is easily removed from the hardened concrete element, if it has been sufficiently greased before concreting. **We recommend not nailing the recess former to the formwork if this can be avoided.**

Floating installation

Application: columns, beams, trusses, π-slabs
Installation aid: **H2 Holding plate**

Installation:

Open up the A1 Recess former ② insert the anchor ①, press the H2 Holding plate ③ into the recess former and press into the wet concrete.

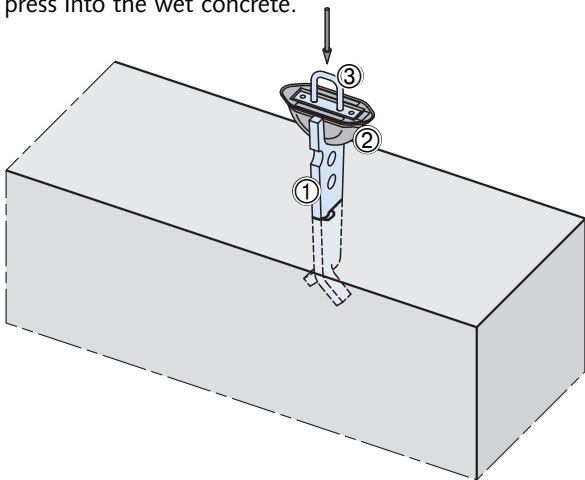

Installation to formwork (wood/steel)

Installation aid: **S1 or S2 Holding bolt**

Installation:

Drill through the formwork, push the S1 or S2 Holding bolt through the hole ⑤, screw into the A1 Recess former ②, with the anchor ① inserted, pull towards the formwork and tighten securely against the formwork with the second wing nut.

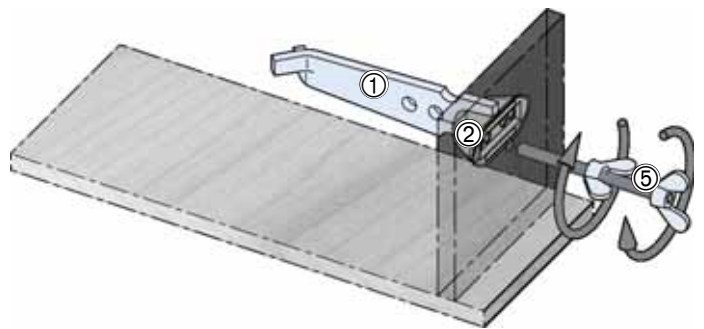

Installation to formwork (steel)

Installation accessory: **HM Magnetic plate**

Installation:

The magnetic holding plate ⑥ is placed and secured at the correct position on the formwork. Press the A1 Recess former ②, with the anchor ① inserted onto the pins.

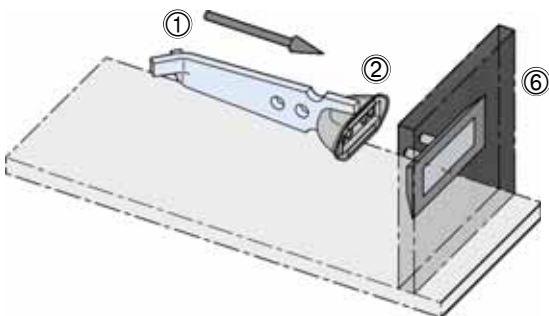

Installation to formwork (wood)

Installation accessory: **H1 Holding plate**

Installation:

Nail or screw the H1 Holding plate ④ onto the formwork. Press the A1 Recess former ② with the anchor ① inserted onto the holding plate.

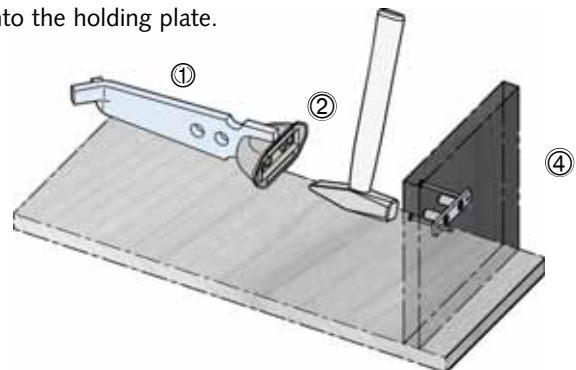

HALFEN FRIMEDA LIFTING ANCHOR SYSTEM

Accessories – Installation and Application

TPA-V1 Recess filler (Polystyrene)

Use polystyrene recess formers to seal and fill a anchor recess in precast concrete. This protects the anchor against corrosion and also prevents water collecting and consequently freezing in cold weather.

The HALFEN TPA-V1 Recess filler can be used during transport and storage or for a permanent seal after final installation.

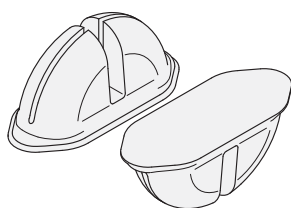

Recess filler TPA-V1

Installation of the recess filler

Hot-dip galvanized or stainless steel anchors can be used, if corrosion protection is required. If not available, two alternative methods of corrosion protection are illustrated below.

- **Method 1:** The recess in the precast element is filled with mortar.

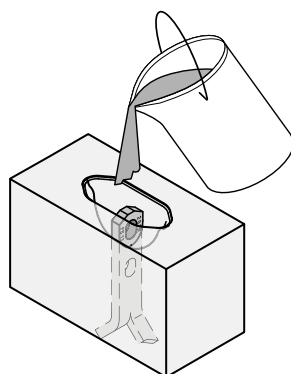

Method 1: Fill with mortar

TPA-V1 Recess filler

Load class	Article number	Order no. 0073.080-
2,5	TPA-V1 2,5	00001
5,0	TPA-V1 5,0	00002
10,0	TPA-V1 10,0	00003

- **Method 2:** The polystyrene (TPA-V1) recess filler is placed over the anchor and pressed into the recess.

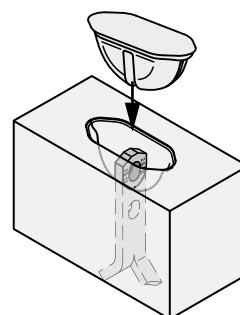

Method 2: With a TPA-V1

TPA-A Z01 Foam strip (for TPA-A4 Recess former)

The anchor head is pressed into the foam strip and then inserted into the recessed TPA-A4 Recess former. Not using a TPA-A Z01 Foam strip results in concrete seeping into the recess.

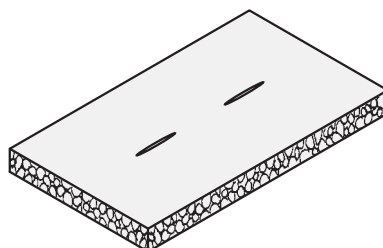

Foam strip for load classes 2,5 – 26,0

Foam strip

Load class	Article number	Order no. 0072.120-
2,5	TPA-A-Z1 2,5	00006
5,0	TPA-A-Z1 5,0	00007
10,0	TPA-A-Z1 10,0	00008
26,0	TPA-A-Z1 26,0	00009

TPA-A E01 Replacement wedge (for TPA-A4 Recess former)

The wedge is used to attach the anchor to the TPA-A4 Recess former. Take the wedge out to remove the recess former. The wedge is supplied with the recess former. Replacement wedges can also be ordered separately.

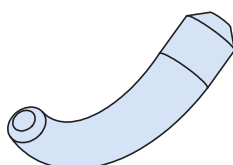

TPA-A-E1 Replacement wedge for load classes 2,5 – 26,0

Replacement wedge

Load class	Article number	Order no. 0072.120-
2,5	TPA-A-E1 2,5	00002
5,0	TPA-A-E1 5,0	00003
10,0	TPA-A-E1 10,0	00004
26,0	TPA-A-E1 26,0	00005

HALFEN FRIMEDA LIFTING ANCHOR SYSTEM

Recess Formers

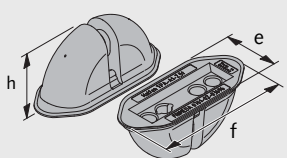
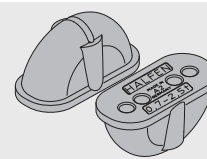
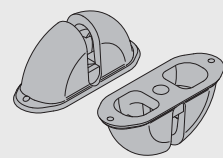
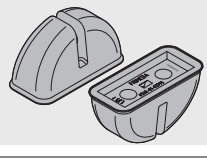
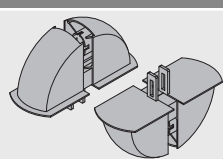
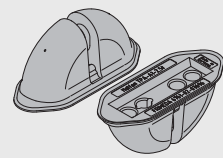
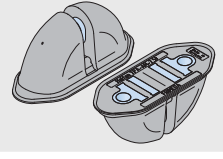
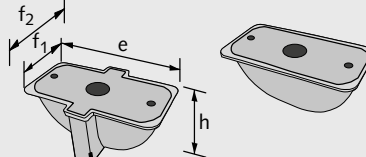
TPA-A1 Plastic recess former								
Colour code	Load class	Article number	Order no. 0072.010-	e [mm]	f [mm]	h [mm]	Thread M	
orange	2,5	TPA-A1 2,5	00001	43	104	45	8	
black	5,0	TPA-A1 5,0	00002	49	126	59	8	
green	10,0	TPA-A1 10,0	00003	67	188	85	12	
blue	26,0	TPA-A1 26,0	00004	112	234	118	16	
for all anchor types except FU, FG								
TPA-A2 Rubber recess former								
Colour code	Load class	Article number	Order no. 0073.020-	e [mm]	f [mm]	h [mm]		
black	2,5	TPA-A2 2,5	00001	41	102	47		
	5,0	TPA-A2 5,0	00002	51	126	59		
	10,0	TPA-A2 10,0	00003	70	184	84		
for all anchor types except FA, FE, FX, FU, FG								
TPA-A4 Plastic recess former (incl. TPA-A E01)								
Colour code	Load class	Article number	Order no. 0072.040-	e [mm]	f [mm]	h [mm]	Thread M	
orange	2,5	TPA-A4 2,5	00001	37	102	45	8	
black	5,0	TPA-A4 5,0	00002	48	126	59	8	
green	10,0	TPA-A4 10,0	00003	70	184	84	12	
blue	26,0	TPA-A4 26,0	00004	112	252	118	16	
for all anchor types except FU, FG								
TPA-A7 Plastic recess former								
Colour code	Load class	Article number	Order no. 0073.070-	e [mm]	f [mm]	h [mm]		
blue	1,25	TPA-A7 1,25	00001	28	60	32		
only for anchor type FU								
TPA-A8 Plastic recess former (for single-use only)								
Colour code	Load class	Article number	Order no. 0073.080-	e [mm]	f [mm]	h [mm]		
orange	2,5	TPA-A8 2,5	00001	42	100	47		
for all anchor types except FU								
TPA-A9 Plastic recess former								
Colour code	Load class	Article number	Order no. 0072.090-	e [mm]	f [mm]	h [mm]	Thread M	
orange	2,5	TPA-A9 2,5	00001	43	104	45	8	
black	5,0	TPA-A9 5,0	00002	49	126	59	8	
green	10,0	TPA-A9 10,0	00003	67	188	85	12	
blue	26,0	TPA-A9 26,0	00004	112	234	118	16	
for all anchor types except FA, FE, FX, FU, FG								
TPA-AM Magnetic recess former								
Colour code	Load class	Article number	Order no. 0072.100-	e [mm]	f [mm]	h [mm]		
orange	2,5	TPA-AM 2,5	00001	43	104	45		
black	5,0	TPA-AM 5,0	00002	49	126	59		
for all anchor types except FU, FG								
TPA-SCFS /-SCFA Plastic recess former								
Load class	Article number	Order no. 0072.150-	e [mm]	f (f ₁ /f ₂) [mm]	h [mm]			
3,0	TPA-SCFA-...	00002	128	65/80	59			
5,0	TPA-SCFA-...	00003	128	65/80	59			
3,0-5,0	TPA-SCFS-...	00004	124	58	59			
7,5	TPA-SCFA-...	00005	158	80/95	85			

HALFEN FRIMEDA LIFTING ANCHOR SYSTEM

Accessories

TPA-H1 Holding plate (for TPA-A1, TPA-A7, TPA-A9 Recess formers)

Load class	Article number	Order no. 0073.010-	e [mm]	f [mm]	t [mm]	d [mm]
1,25	TPA-H1 1,25	00001	40	15	3	8
2,5	TPA-H1 2,5	00002	70	15	4	10
5,0	TPA-H1 5,0	00003	85	30	4	10
10,0	TPA-H1 10,0	00004	125	45	4	12
26,0	TPA-H1 26,0	00005	175	65	4	16

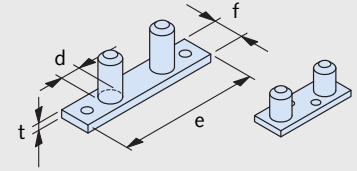

TPA-H2 Holding plate (for floating installation of TPA-A1, TPA-A9 Recess formers)

Load class	Article number	Order no. 0073.020-	e [mm]	f [mm]	t [mm]	d [mm]
2,5	TPA-H2 2,5	00001	70	15	4	10
5,0	TPA-H2 5,0	00002	85	30	4	10
10,0	TPA-H2 10,0	00003	125	45	4	12
26,0	TPA-H2 26,0	00004	178	65	4	16

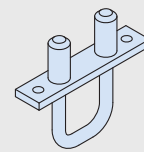
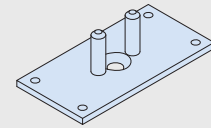

Figure: type load class 1,25

TPA-H3 Holding plate (for TPA-A2 Recess former)

Load class	Article number	Order no. 0073.030-	e [mm]	f [mm]	t [mm]	d [mm]
2,5	TPA-H3 2,5	00001	100	50	4	8
5,0	TPA-H3 5,0	00002	120	60	4	8
10,0	TPA-H3 10,0	00003	170	80	4	12



TPA-HM Magnet holding plate (for TPA-A1, TPA-A9 Recess formers)

Load class	Article number	Order no. 0073.050-	e [mm]	f [mm]	t [mm]	d [mm]
2,5	TPA-HM 2,5	00001	144	63	16	10
5,0	TPA-HM 5,0	00002	144	63	16	10
10,0	TPA-HM 10,0	00003	220	125,5	16	12

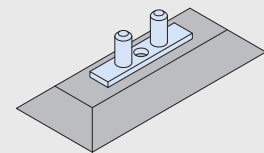

TPA-S1 Holding bolt with wing nut (for TPA-A1, TPA-A2, TPA-A7, TPA-A9 Recess formers and TPA-H3 Holding plate)

Load class	Article number	Order no. 0073.060-	l [mm]	M
1,25	TPA-S1 M8	00001	160	M8
2,5				
5,0				
10,0	TPA-S1 M12	00002	160	M12
26,0	TPA-S1 M16	00003	180	M16

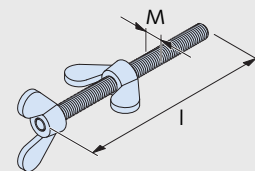

TPA-S2 Bayonet holding bolt (for TPA-A1, TPA-A9 Recess formers)

Load class	Article number	Order no. 0073.070-	l [mm]	a [mm]	M
2,5	TPA-S2 M8	00001	160	11	M8
5,0					
10,0	TPA-S2 M12	00002	180	16	M12
26,0					

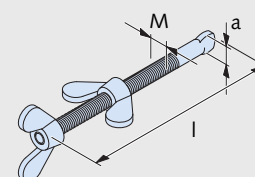

HALFEN FRIMEDA LIFTING ANCHOR SYSTEM

TPA Ring Clutches – Application

HALFEN FRIMEDA Ring clutch: Application instructions

Removing formwork sections

Before lifting the precast concrete element, as many sections of the formwork as possible should be removed to minimise adhesion to the formwork. Inadequate removal of formwork is the most common cause of flaking in precast concrete elements and anchor failure. Otherwise the forces acting on the lifting system can be several times the actual weight of the precast element.

Attaching the ring clutch

When transporting an element the appropriate ring clutch for the load group is inserted over the anchor head in the concrete recess. Selecting the wrong ring clutch for the load class is not possible.

Tilt-up of slabs without a tilt-up table

The HALFEN FRIMEDA Lifting anchor system can be used to lift horizontal manufactured precast elements from the horizontal to the vertical. The load direction is at right-angles to the cast-in anchor. To avoid damage to the concrete the TPA-FA Tilt-up anchor should be installed in the precast element.

Attaching the lifting devices

A main benefit of the HALFEN FRIMEDA Lifting anchor system is that the clutch (ring clutches) remain attached to the crane hook and doesn't need to be moved by hand. When not subjected to load, the ring clutch can be released manually by pushing back the locking bolt.

Removing the recess formers

Two rods are inserted in the holes in the recess former, which is removed from the concrete using a scissor motion. Using only this technique maximize the life span of the recess former. Attempting to remove the recess former using a hammer claw or other sharp tools will damage the recess former.

Securing the ring clutch

The ring clutch is securely locked by hand; push the locking bolt fully down to the concrete. The resulting connection is secure, and the ring clutch free to move in any direction. The precast element can be lifted out of the formwork and transported safely to its point of storage.

Load class ring clutch	Load class anchor
1,25	1,25
2,5	1,4
	2,5
5,0	5,0
10,0	7,5
	10,0
26,0	12,5
	14,0
	17,0
	22,0
	26,0

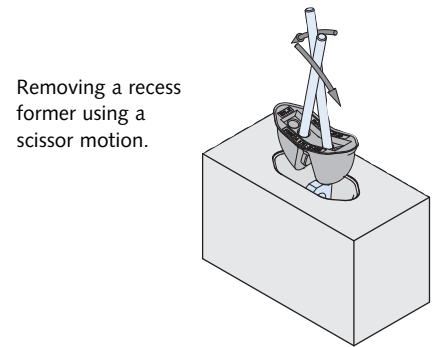

Removing a recess former using a scissor motion.

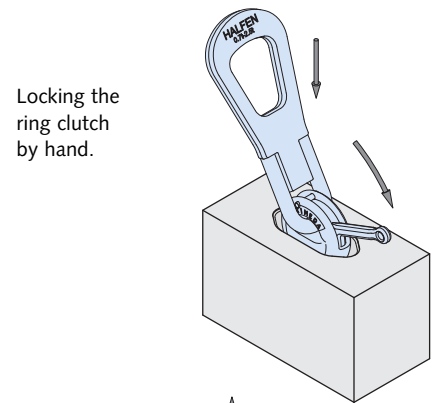

Locking the ring clutch by hand.

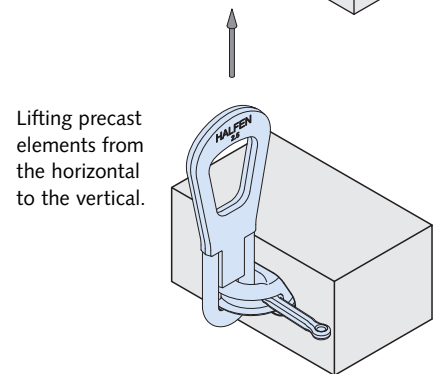

Lifting precast elements from the horizontal to the vertical.

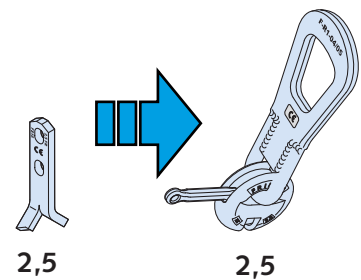

Only the correct lifting link fits into the appropriate anchor!

HALFEN FRIMEDA LIFTING ANCHOR SYSTEM TPA Ring Clutches – Application

Correct use of the HALFEN FRIMEDA R1 Ring clutch

1. Engaging

Insert the ring clutch in the recess in the concrete and close the locking bolt (the latch) manually, pushing it fully down to the concrete. The element can now be lifted.

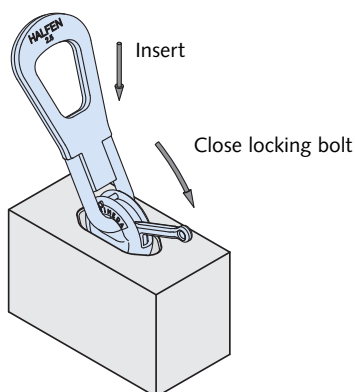

2. Handling

The ring clutch can be subjected to loads in any direction (do not exceed the load limits of the anchors!).

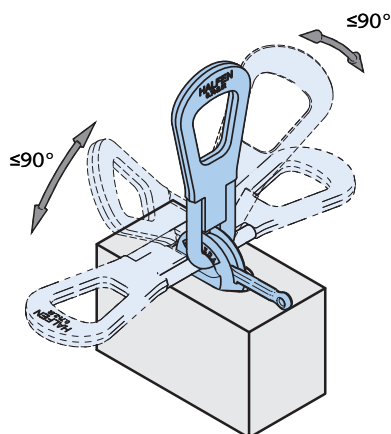

3. Disengaging

Manual ring clutch: push the bolt back by hand. The ring clutch is now disengaged.

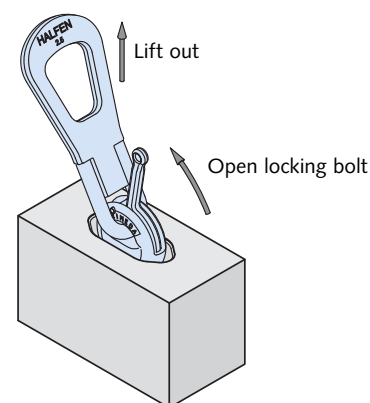

In-correct application of the HALFEN FRIMEDA Ring clutch

⊗ Shackle is restricted

If the shackle is caught under the clutch head when subjected to load, it may lock in the position illustrated. The shackle will deform when subjected to load.

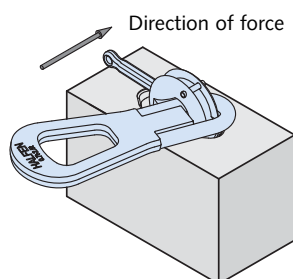

Problem: Shackle is restricted

⊗ Edge of slab shackle damage

If the shackle is pulled towards the top surface of the slab when subjected to load it may bend at the slab edge.

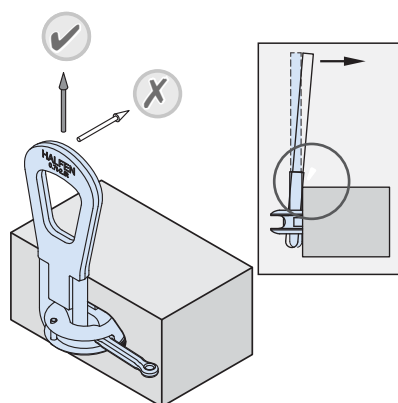

Problem: Shackle will bend at this point and cause damage

⊗ Clutch blocks the shackle

In the upper position, the shackle can lock in the clutch. A small lifting cable angle will cause the shackle to bend. The problem is prevented by turning the shackle through approx. 45°.

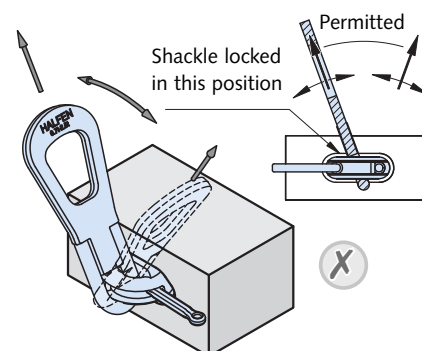

Shackle can't lock in this position

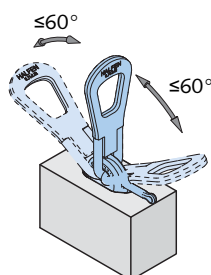

Attention!

Diagonal pull caused by cable/chain spread is permitted up to 60°.

HALFEN FRIMEDA LIFTING ANCHOR SYSTEM

TPA-R1 Ring Clutch and TPA Cable Loops

TPA-R1 Ring clutch with shackle for manual release

The ring clutch consists of a shackle and a clutch head. The shackle is freely moveable in all directions. The clutch head incorporates a locking bolt that engages in an anchor, which is cast in a recess in the concrete. The locking bolt is corrosion protected.

The allowable loads for each application are selected from the respective table for the anchor type. All lifting link safety regulations in the country of use must always be observed, in particular those for the use of cranes and lifting equipment.

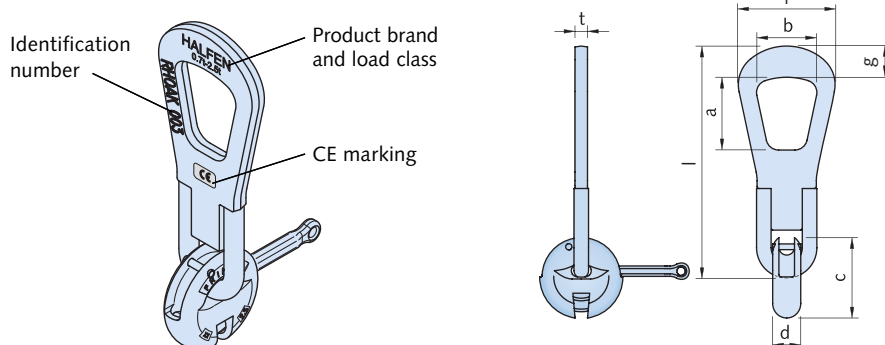

TPA-R1											
Load class	Article number	Order no. 0071.010-	l [mm]	a [mm]	b [mm]	c [mm]	d [mm]	t [mm]	f [mm]	g [mm]	Weight [kg]
2,5	TPA R1 2,5	00001	225	70	58	80	27	12	93	30	1.6
5,0	TPA R1 5,0	00002	275	86	65	105	36	16	114	40	3.6
10,0	TPA R1 10,0	00006	350	112	90	150	50	25	148	50	9.2
26,0	TPA R1 26,0	00007	500	160	120	206	72	30	208	70	25.9

Ring clutches with cable loops TPA-R2 (for load classes 1,25 / 2,5 / 5,0 / 10,0) TPA-R3 (for load class 26,0)

As with all other lifting and hoisting systems, ring clutches with cable loops are subject to inspection by experts to ensure safe application at least once a year. Any damaged cables must be discarded in strict accordance with the relevant accident prevention regulations for lifting equipment.

If required, worn cable loops with ferule can be replaced by Leviat as the clutch head generally have a much longer life-span than the cable loops.

The allowable loads for each application are selected from the respective table for the anchor type. Lifting link safety regulations in the country of use must always be observed, in particular those for the use of cranes and lifting equipment.

TPA-R2 load class 1,25 - 10,0

TPA-R3 load class 26,0

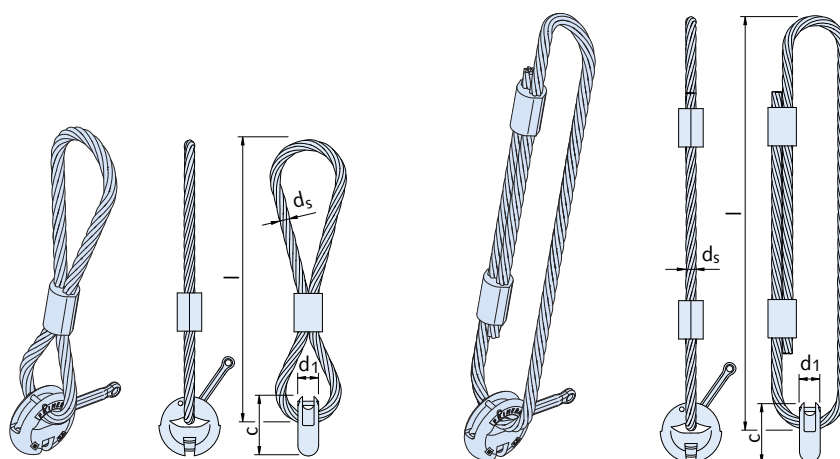

TPA-R2 / TPA-R3							
Load class	Article number	Order no. 0071.020-	l [mm]	c [mm]	d ₁ [mm]	d _s [mm]	Weight [kg]
1,25	TPA R2 1,25	00001	~320	52	20	∅ 8	0.4
2,5	TPA R2 2,5	00002	~560	80	27	∅ 14	1.8
5,0	TPA R2 5,0	00003	~595	105	36	∅ 18	3.5
10,0	TPA R2 10,0	00006	~702	150	50	∅ 22	7.8
26,0	TPA R3 26,0	00007	~1570	206	72	∅ 32	25.0

HALFEN FRIMEDA LIFTING ANCHOR SYSTEM

TPA, TPA-R2, TPA-R3 Ring Clutches / Limit Values, Checking the Anchor

Tolerances for the TPA-R1 Ring clutch

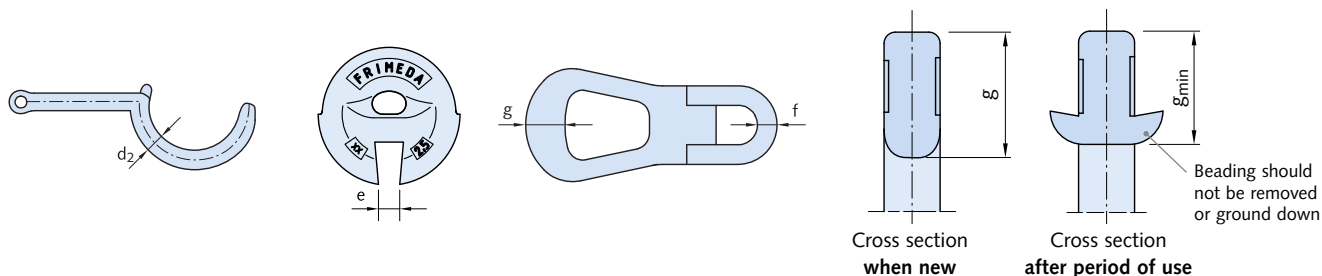

Load class	Nominal dimension d_2 [mm]	Minimum dimension d_2 [mm]	Nominal dimension e [mm]	Maximum dimension e [mm]	Nominal dimension f [mm]	Minimum dimension f [mm]	Nominal dimension g [mm]	Minimum dimension g_{min} [mm]
1,25	8.0 +0.4/-0.6	7	7.0 ±0.12	8	-	-	-	-
2,5	13.0 +0.7/-0.4	12	12.0 ±0.5	14	14 ± 0.4	12.5	30	22.5
5,0	16.5 +0.7/-0.4	15	18.0 +0.5/-1.0	20	20 ± 0.6	18.5	40	30
10,0	23.5 +0.8/-0.4	22	22.0 ±0.5	24	26 ± 0.8	24	50	40
26,0	32.0 +0.9/-0.5	30.5	34.0 +2.0/-1.0	38	40 ± 1.0	38	70	56

i These dimensions are valid for clutches with shackle and with wire cables.



Bent shackles must not be straightened. The HALFEN FRIMEDA Ring clutch has to be discarded if the shackle has a significant deflection.

Figure: Significant bending of the shackle caused by misuse of a TPA Ring clutch

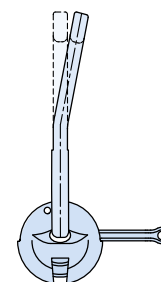

Checking the Lifting Links

Wire cables (TPA-R2/R3)

Wire cables should be checked for the following defects:

- kinking and buckling
- broken cable braid
- slackening of the outermost exposed layer in a free length
- compressed deformation
- compression in the loop with more than four broken wires in braided cables, or more than ten broken wires in cable-laid products
- corrosion scarring
- damage or severe wear to the cable connector or cable-end connector
- excessive number or broken wires



Discarding the cable

Cable type	Discard the cable if the following number of broken wires is visible over a cable length of:		
	$3d_s$	$6d_s$	$30d_s$
Strand cable	4	6	16

Wire cable inspections include checking for signs of cable slippage in the ferule. Acids, alkalis and other aggressive media that can cause corrosion must be kept away from cables. Cable loops should preferably be used with crane hooks with large section diameter. Sharp-edged hooks or hooks with small cross-section and therefore small radii will damage the cable loops.

Clutch heads with worn cable loops can be re-pressed by us as the clutch heads generally have a longer service life than the cable loops.

HALFEN FRIMEDA LIFTING ANCHOR SYSTEM

TPA-F1 TPA Ring Clutches

TPA-F1 Ring clutch with pneumatic release

Operating principle

The pneumatically operated remote-control release mechanism has been designed as an alternative to the manual release for distances of more than 10 metres. On the pneumatic version, the locking bolt is released using compressed air.

The compressed air (max. 7 bar) can be supplied from any suitable source, e. g. a site compressor or a portable unit. A hand valve in the air-feed line allows the ring clutch to be opened (Dead man's switch). Further air-feed lines can be connected; this depends on the number of ring clutches in use.

Operating sequence

The ring clutch is inserted in the concrete recess and engaged by closing the locking bolt by hand. The precast element can now be lifted.

To disengage the clutch (e.g. after installing concrete columns) the hand valve is opened, allowing compressed air into the cylinder pushing the locking bolt back to open the clutch. There is no risk of unintentional release, as the locking bolt remains closed in the event of air supply failure. The air cylinder for the system was selected to prevent bolt release if the attached load is greater than 0.2 t. Compressed air is only released if the key in the hand valve is turned in the direction of the arrow and held in the open position.

As soon as the key is released, even if it still in the keyhole, the valve is automatically closed and the air in the feed-line can escape. To ensure satisfactory operation we recommend that the air-feed lines to the cylinders are installed in the crane or crane jib. If the compressed air is fed to the precast unit directly from ground level, the air-feed between the compressor and the remote control may only be connected when it is time to release the clutch; e.g. when a column is in its final position and secured.

Remote-release ring clutches have the same markings as manual ring clutches.

TPA-F1			
Load class	Article number	Order no. 0071.030-	Weight [kg]
2,5	TPA-F1 2,5	00001	3.0
5,0	TPA-F1 5,0	00002	6.0
10,0	TPA-F1 10,0	00003	13.7
26,0	TPA-F1 26,0	00004	37.5



According to the instructions on page 54 all lifting devices have to be regularly checked!

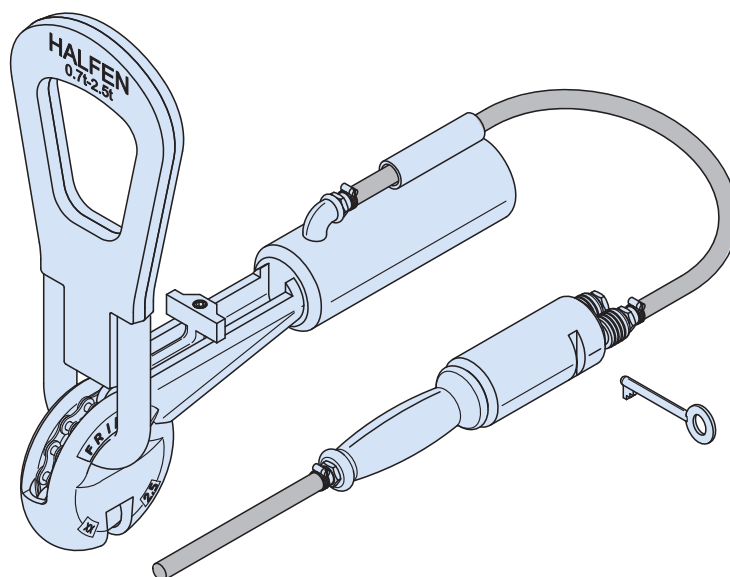

HALFEN FRIMEDA LIFTING ANCHOR SYSTEM

TPA, TPA-F1 Ring Clutches

TPA-F1 Accessories

Design
Single lift

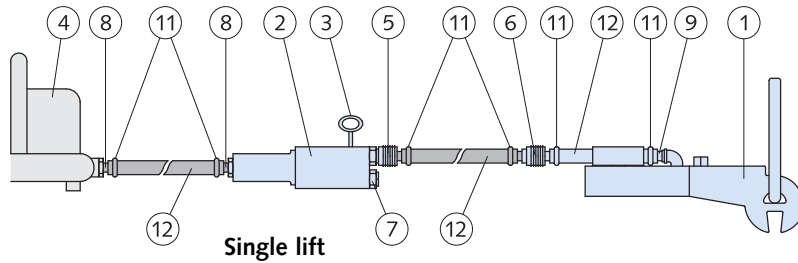

Design
Double lift

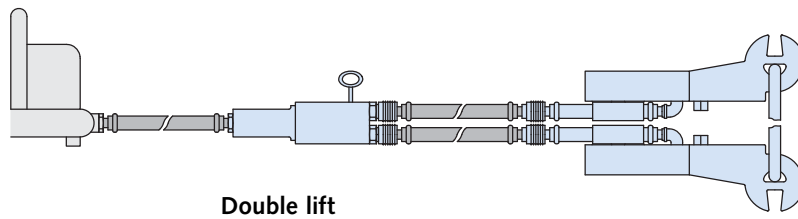

Design
Four-point lift

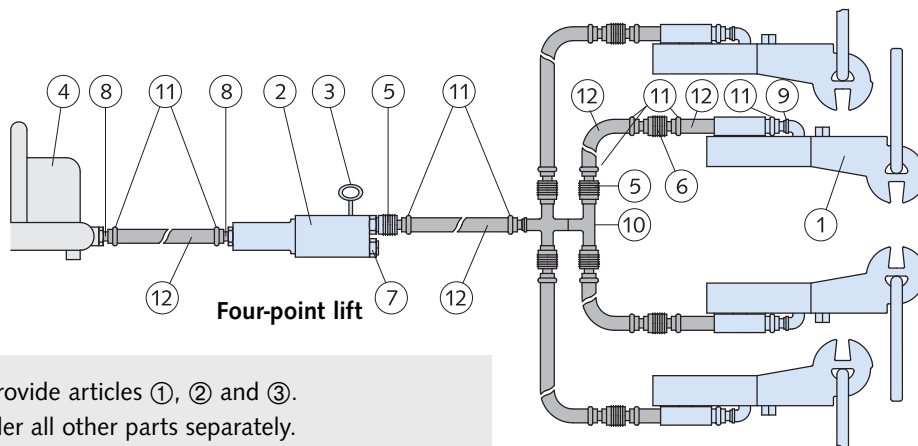

We can provide articles ①, ② and ③.
Please order all other parts separately.

Accessories					
Position	Description	Order no. 0071.070-	Accessories required for:		
			Single lift	Double lift	Four-point lift
①	Ring clutch; complete	see page 54	1	2	4
②	Hand valve	00004	1	1	1
③	Key	00005	1	1	1
④	Compressor	-	1	1	1
⑤	Quick-action hose coupler R 1/4"	-	2	2	5
⑥	as position 5, but dual hose	-	2	2	4
⑦	Thread plug R 1/4"	-	-	-	1
⑧	Coupler R 3/8"	-	2	2	2
⑨	Coupler R 1/4"	-	2	2	4
⑩	4-way distributor	-	-	-	1
⑪	Hose clip	-	6	10	20
⑫	Fabric hose	-	as required	as required	as required

HALFEN FRIMEDA LIFTING ANCHOR SYSTEM TPA, TPA-F2 Ring Clutches

TPA-F2 Ring clutch with Bowden cable, manual remote control

Operating principle

The remote-control is used to open the ring clutch from a safe distance of up to 10 metres. A Bowden cable connected to the locking bolt at the ring clutch serves as a release mechanism. At the opposite end, the release handle is secured to the tube with a safety catch. All TPA-F2 Clutch heads in the various load groups have the same M27 thread, i.e. the remote-control mechanism fits any clutch head. The opening and closing mechanism, comprising of the locking bolt, the shackle with indicator and the latch are parts of the clutch head.

Operation of the manual remote-control

To release the ring clutch, disengage the handle by pressing and turning. Unintentional release is not possible. For safety and efficiency reasons, the locking bolt is closed by hand. The remote device is designed so the locking bolt cannot be closed remotely. The flexible tube can withstand reasonable tension and compression loads, so that the precast unit is easy to manoeuvre.

The ring clutches of all the load groups can be used with any of the manual remote-control releases of 2.5 m, 5.0 m, 7.5 m and 10.0 m lengths.

TPA-F2				
Load class	Article number	Order no. 0071.040-	Cable length [m]	Weight [kg]
2,5	TPA-F2 2,5	00001	2.5	5.4
		00002	5.0	6.5
		00003	7.5	8.9
		00004	10.0	10.6
5,0	TPA-F2 5,0	00005	2.5	8.0
		00006	5.0	9.1
		00007	7.5	11.5
		00008	10.0	13.2
10,0	TPA-F2 10,0	00009	2.5	15.2
		00010	5.0	16.3
		00011	7.5	18.7
		00012	10.0	20.4
26,0	TPA-F2 26,0	00013	2.5	37.5
		00014	5.0	38.6
		00015	7.5	41.0
		00016	10.0	42.7



All lifting devices have to be regularly checked in accordance with the instructions on page 54!

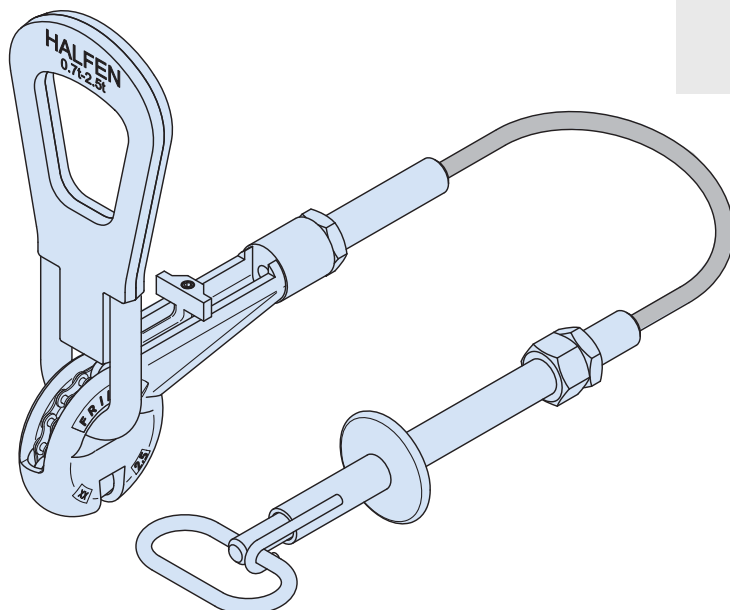

HALFEN FRIMEDA LIFTING ANCHOR SYSTEM TPA, TPA-F2 Ring Clutches

Component parts for TPA-F2

All clutch heads in the various load groups have an M27 inner thread; this allows connection of different cables lengths and various clutch heads to the remote-control mechanism.

This allows the individual components of the remote-control mechanism to be ordered separately; and also helps to reduce storage space requirements.

As with all lifting devices, remote-control mechanisms must be checked regularly by an expert (see page 54, "Checking the lifting links"). Worn locking bolts can be replaced. Other repairs are not permitted.

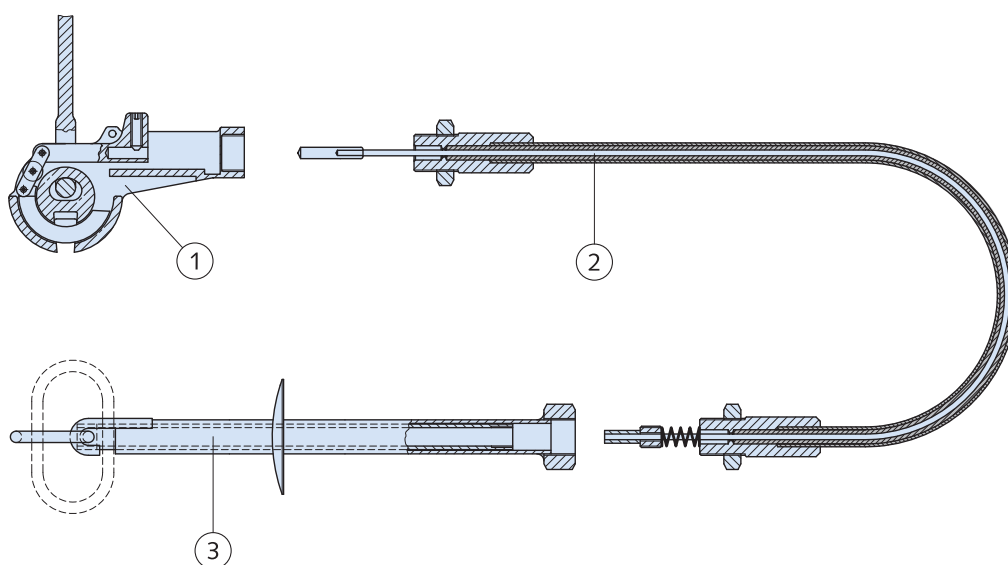

- ① Clutch unit
- ② Pull cable unit
- ③ Release handle and tube

① TPA-F2-KUP Clutch unit		
Load class	Article number	Order no. 0071.080-
2,5	TPA-F2-KUP- 2,5	00001
5,0	TPA-F2-KUP- 5,0	00002
10,0	TPA-F2-KUP-10,0	00003
26,0	TPA-F2-KUP-26,0	00004

② TPA-F2-SZE Pull cable unit		
Article number	Order no. 0071.080-	Cable length
TPA-F2-SZE- 2,5	00005	2.5 m
TPA-F2-SZE- 5,0	00006	5.0 m
TPA-F2-SZE- 7,5	00007	7.5 m
TPA-F2-SZE- 10,0	00008	10.0 m

③ TPA-F2-GRI Release handle and tube	
Article number	Order no.
TPA-F2-GRI	0071.080-00009

FURTHER PRODUCTS

HALFEN DEHA KKT Spherical Head Anchor

The HALFEN DEHA Lifting anchor system is cast into the concrete together with a recess former which will be subsequently removed. The quick and easy universal head link is used to lift the concrete element.



Quality features:

- › safe, quick, efficient
- › anchor length identification remains visible even after installation
- › abrasion resistant clutch
- › for all forms and sizes of precast elements
- › load class 1,3 to 45,0
- › lifting hook can also be ordered with a certificate
- › CE marked in accordance with the EU machinery directive guide lines since April 2012



FURTHER PRODUCTS

HALFEN HD Socket Lifting System

The new generation of lifting system with protective cap and integrated identification cap covers the HD Socket load range up to 25 tonnes with only nine load groups. The anchor sleeve is also available in stainless steel.



The anchor sleeve protection system remains permanently in the sleeve and offers protection against all type of dirt or other foreign objects.

Quality features:

- › efficient product range for load class 1,3 up to 25,0
- › integrated sleeve protection with identification cap
- › robust lifting clutch for increased safety and economy
- › lifting clutch can also be ordered with a certificate
- › CE marked since April 2012 (acc. to EU machinery directive guidelines)









Leviat[®]
A CRH COMPANY

Innovative engineered products and construction solutions that allow the industry to build safer, stronger and faster.



Worldwide contacts for Leviat:

Australia

Leviat
98 Kurrajong Avenue,
Mount Druitt, Sydney, NSW 2770
Tel: +61 - 2 8808 3100
Email: info.au@leviat.com

Austria

Leviat
Leonard-Bernstein-Str. 10
Saturn Tower, 1220 Wien
Tel: +43 - 1 - 259 6770
Email: info.at@leviat.com

Belgium

Leviat
Borkelstraat 131
2900 Schoten
Tel: +32 - 3 - 658 07 20
Email: info.be@leviat.com

China

Leviat
Room 601 Tower D, Vantone Centre
No. A6 Chao Yang Men Wai Street
Chaoyang District
Beijing · P.R. China 100020
Tel: +86 - 10 5907 3200
Email: info.cn@leviat.com

Czech Republic

Leviat
Business Center Šafránková
Šafránková 1238/1
155 00 Praha 5
Tel: +420 - 311 - 690 060
Email: info.cz@leviat.com

Finland

Leviat
Vädursgatan 5
412 50 Göteborg / Sweden
Tel: +358 (0)10 6338781
Email: info.fi@leviat.com

France

Leviat
18, rue Goubet
75019 Paris
Tel: +33 - 1 - 44 52 31 00
Email: info.fr@leviat.com

Germany

Leviat
Liebigstrasse 14
40764 Langenfeld
Tel: +49 - 2173 - 970 - 0
Email: info.de@leviat.com

India

Leviat
309, 3rd Floor, Orion Business Park
Ghodbunder Road, Kapurbawdi,
Thane West, Thane,
Maharashtra 400607
Tel: +91 - 22 2589 2032
Email: info.in@leviat.com

Italy

Leviat
Via F.lli Bronzetti 28
24124 Bergamo
Tel: +39 - 035 - 0760711
Email: info.it@leviat.com

Malaysia

Leviat
28 Jalan Anggerik Mokara 31/59
Kota Kemuning, 40460 Shah Alam
Selangor
Tel: +603 - 5122 4182
Email: info.my@leviat.com

Netherlands

Leviat
Oostermaat 3
7623 CS Borne
Tel: +31 - 74 - 267 14 49
Email: info.nl@leviat.com

New Zealand

Leviat
2/19 Nuttall Drive, Hillsborough,
Christchurch 8022
Tel: +64 - 3 376 5205
Email: info.nz@leviat.com

Norway

Leviat
Vestre Svanholmen 5
4313 Sandnes
Tel: +47 - 51 82 34 00
Email: info.no@leviat.com

Philippines

Leviat
2933 Regus, Joy Nostalg,
ADB Avenue
Ortigas Center
Pasig City
Tel: +63 - 2 7957 6381
Email: info.ph@leviat.com

Poland

Leviat
Ul. Obornicka 287
60-691 Poznań
Tel: +48 - 61 - 622 14 14
Email: info.pl@leviat.com

Singapore

Leviat
14 Benoi Crescent
Singapore 629977
Tel: +65 - 6266 6802
Email: info.sg@leviat.com

Spain

Leviat
Polígono Industrial Santa Ana
c/ Ignacio Zuloaga, 20
28522 Rivas-Vaciamadrid
Tel: +34 - 91 632 18 40
Email: info.es@leviat.com

Sweden

Leviat
Vädursgatan 5
412 50 Göteborg
Tel: +46 - 31 - 98 58 00
Email: info.se@leviat.com

Switzerland

Leviat
Hertistrasse 25
8304 Wallisellen
Tel: +41 (0)800 22 66 00
Email: info.ch@leviat.com

United Arab Emirates

Leviat
RA08 TB02, PO Box 17225
JAFZA, Jebel Ali, Dubai
Tel: +971 (0)4 883 4346
Email: info.ae@leviat.com

United Kingdom

Leviat
A1/A2 Portland Close
Houghton Regis LU5 5AW
Tel: +44 - 1582 - 470 300
Email: info.uk@leviat.com

USA / Canada

Leviat
6467 S Falkenburg Road
Riverview, FL 33578
Tel: (800) 423-9140
Email: info.us@leviat.us

For countries not listed

Email: info@leviat.com

Leviat.com

For information on certified management systems and standards see www.ancon.co.uk | www.aschwanden.com | www.halfen.com

Notes regarding this catalogue

© Protected by copyright. The construction applications and details provided in this publication are indicative only. In every case, project working details should be entrusted to appropriately qualified and experienced persons. Whilst every care has been exercised in the preparation of this publication to ensure that any advice, recommendations or information is accurate, no liability or responsibility of any kind is accepted by Leviat for inaccuracies or printing errors. Technical and design changes are reserved. With a policy of continuous product development, Leviat reserves the right to modify product design and specification at any time.



Imagine. Model. Make.

Leviat.com